

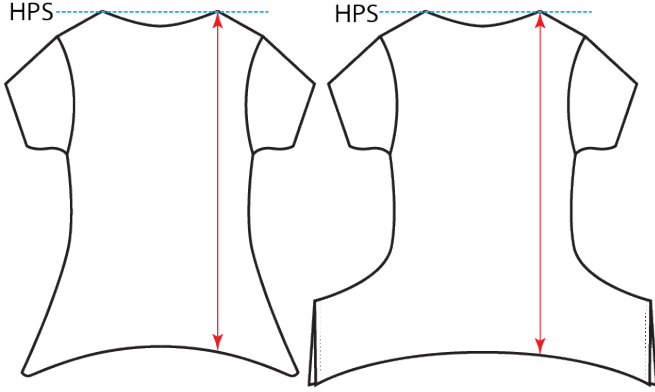

## HTM Guide

	Product Flex # :	144462	Name :	TD Template Product	Flex Spec ID :	91666
	Primary Catalog :		Seasonal Selling Quarter :		Season Name :	Fall 2014
Merchandise :	PC - Chelsea Olm	Product Designer :		Tech Designer :		QA Technologist :
SFC :		Vendor :	GSO TBD	Sourcing :		GSO Tracking # :
Pack Number :		Size Definitions :		Womens Numeric---:6-24W, Womens Alpha---:S-3X, One Size---:One Size-One Size		Vendor Item # :

LT19	Back Length Hankie Hem	LT20	Low Hip Placement From HPS	MP01	Modesty Panel Length at Center
Measure straight from high point shoulder (HPS) to bottom edge.		Measure straight to hip location, parallel to center front, from high point shoulder (HPS).		Measure center of modesty panel straight down from top edge to bottom edge	
					
MP02	Modesty Panel Width Bottom Edge	MP03	Modesty Panel Width Top edge	MP04	Modesty Panel Placement from HPS
Measure modesty panel width at Bottom; from edge to edge		Measure modesty panel width at top; from edge to edge		Measure down from HPS to top edge of modesty panel.	
					

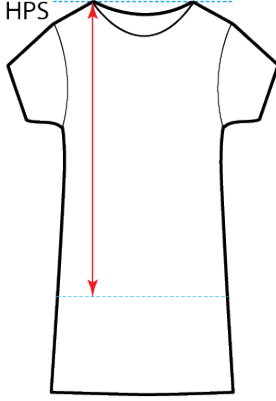
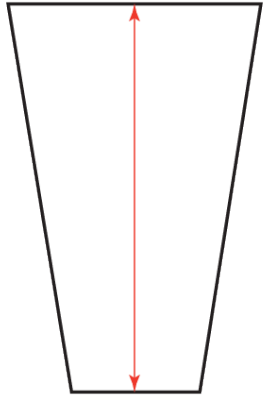
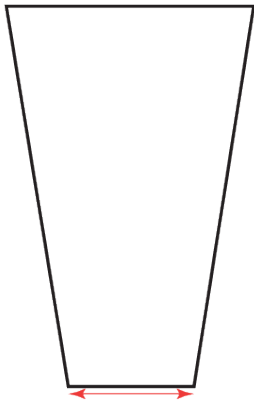
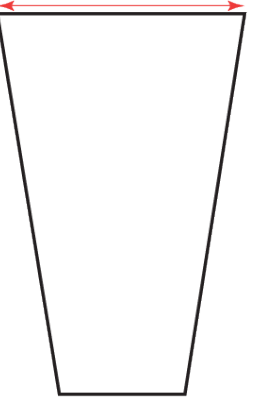
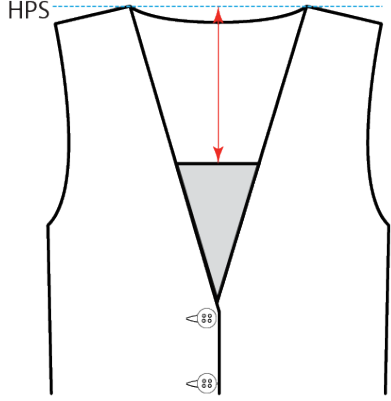

HTM Guide

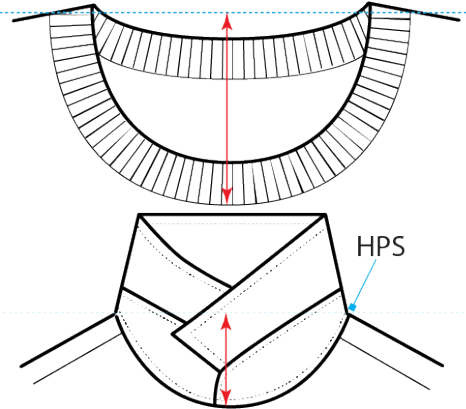
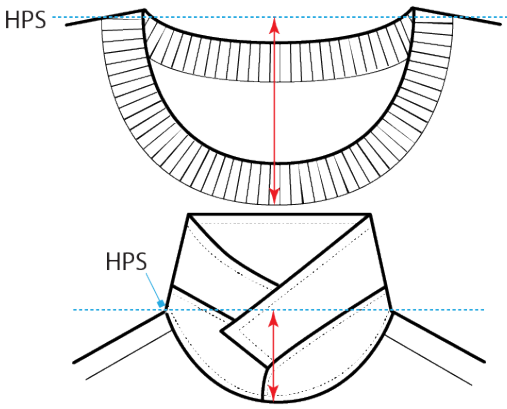
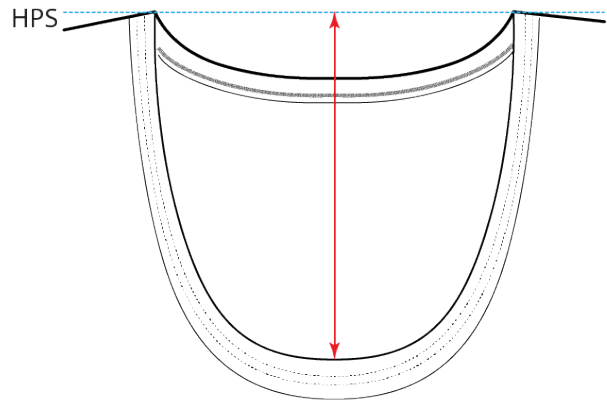
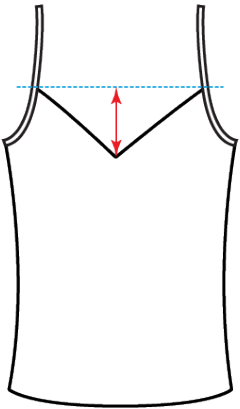
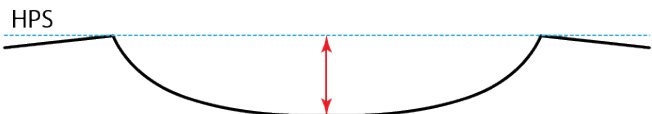
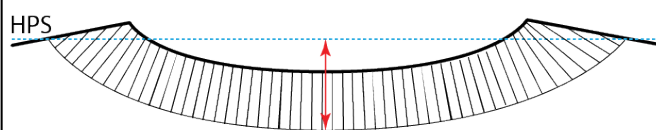
	Product Flex # :	144462	Name :	TD Template Product	Flex Spec ID :	91666
	Primary Catalog :		Seasonal Selling Quarter :		Season Name :	Fall 2014
Merchandiser :	PC - Chelsea Olm	Product Designer :		Tech Designer :		QA Technologist :
SFC :		Vendor :	GSO TBD	Sourcing :		GSO Tracking # :
Pack Number :		Size Definitions :		Womens Numeric---:6-24W, Womens Alpha---:S-3X, One Size---:One Size-One Size		Vendor Item # :

ND01-E	Front Neck Drop From HPS to Top Edge	ND01-S	Front Neck Drop From HPS to Seam	ND02-E	Front Neck Drop from HPS to Chest Edge
<p>Measure from imaginary line at high point shoulder (HPS) at center of garment perpendicular to a) front neck edge, b) front neck collar seam, c) front neck seam (for sweaters w/ rib or tubular join to body seam).</p>		<p>Measure from imaginary line at high point shoulder (HPS) at center of garment perpendicular to a) front neck seam, b) front neck collar seam, c) front neck seam (for sweaters w/ rib or tubular join to body seam).</p>		<p>Measure from imaginary line at high point shoulder (HPS) at center of garment perpendicular to a) front neck edge, b) front neck collar seam (for sweaters w/ rib or tubular join to body seam).</p>	
					
ND03	Front Neck Drop-Strap Miter to edge	ND04-E	Back Neck Drop From HPS to Top Edge	ND04-S	Back Neck Drop From HPS to Seam
<p>Measure from imaginary line at straps edge at center of garment perpendicular to front neck edge.</p>		<p>On the back of the garment, measure from imaginary line at high point shoulder (HPS) at center of garment perpendicular to a) back neck edge, b) back neck collar seam (for sweaters w/ rib or tubular join to body seam).</p>		<p>On the back of the garment, measure from imaginary line at high point shoulder (HPS) at center of garment perpendicular to a) back seam, b) back neck collar seam (for sweaters w/ rib or tubular join to body seam).</p>	
					

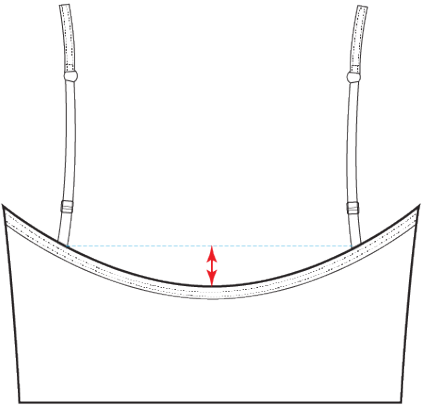
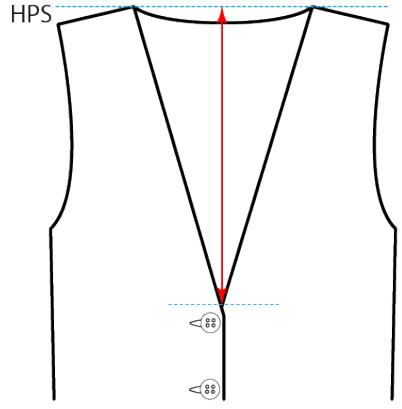

HTM Guide

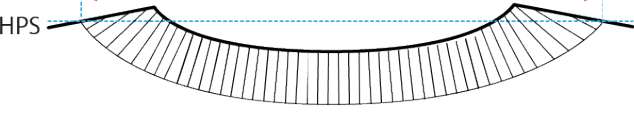
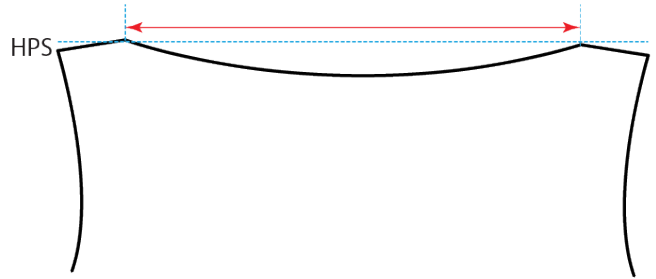
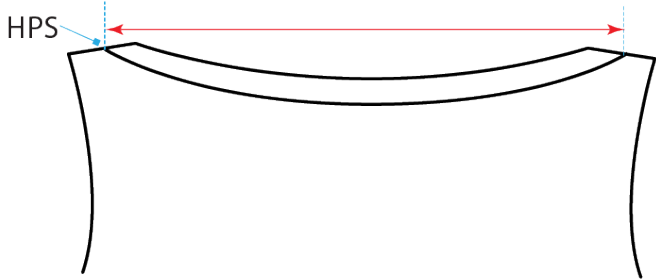
	Product Flex # :	144462	Name :	TD Template Product	Flex Spec ID :	91666
	Primary Catalog :		Seasonal Selling Quarter :		Season Name :	Fall 2014
Merchandiser :	PC - Chelsea Olm	Product Designer :		Tech Designer :		QA Technologist :
SFC :		Vendor :	GSO TBD	Sourcing :		GSO Tracking # :
Pack Number :		Size Definitions :		Womens Numeric---:6-24W, Womens Alpha---:S-3X, One Size---:One Size-One Size	Vendor Item # :	

ND05	Back Neck Drop-Strap Miter to Edge	ND06	Front Neck Drop- HPS to Waist Placement	NK01-E	Neck Width- Edge to Edge
From imaginary line at inside straps edge to edge, measure back neck drop at center of garment perpendicular to edge.		Measure from imaginary line at high point shoulder (HPS) at center of garment perpendicular to front neck edge at waist		On the back of the garment, measure straight across neckline from inside edge to inside edge at high point shoulder (HPS)	
					
NK01-S	Neck Width- Seam to Seam	NK02-E	Neck Width Boat- Edge to Edge	NK02-S	Neck Width Boat- Seam to Seam
On the back of the garment, measure straight across neckline from seam to seam (for sweaters- w/ rib or tubular join to body seam) at high point shoulder (HPS).		On the back of the garment, measure straight across neckline from inside edge to inside edge at high point shoulder (HPS)		On the back of the garment, measure straight across neckline from inside edge to inside edge at high point shoulder (HPS)	
					

HTM Guide

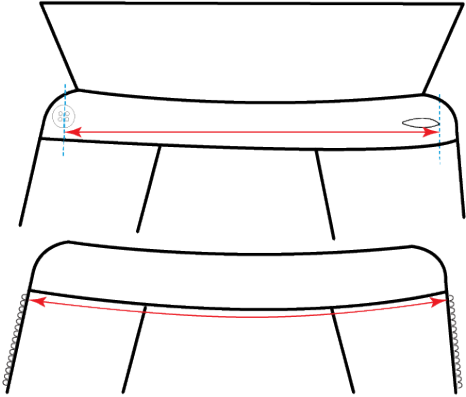
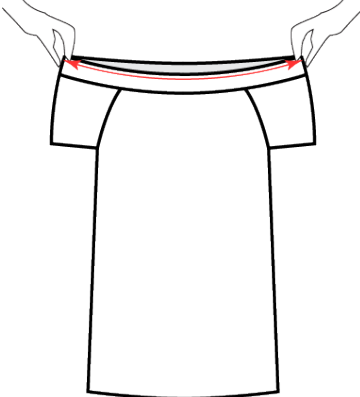
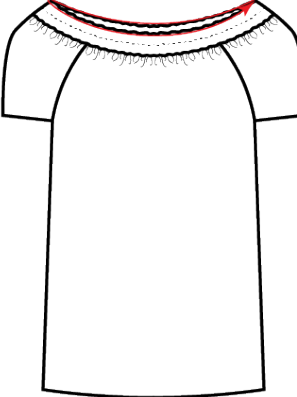
	Product Flex # :	144462	Name :	TD Template Product	Flex Spec ID :	91666
	Primary Catalog :		Seasonal Selling Quarter :		Season Name :	Fall 2014
Merchandiser :	PC - Chelsea Olm	Product Designer :		Tech Designer :		QA Technologist :
SFC :		Vendor :	GSO TBD	Sourcing :		GSO Tracking # :
Pack Number :		Size Definitions :		Womens Numeric---:6-24W, Womens Alpha---:S-3X, One Size---:One Size-One Size		Vendor Item # :

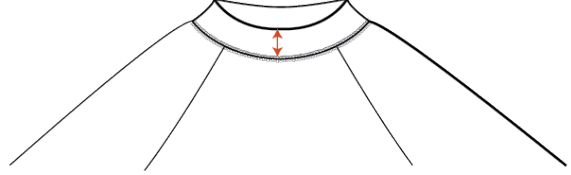
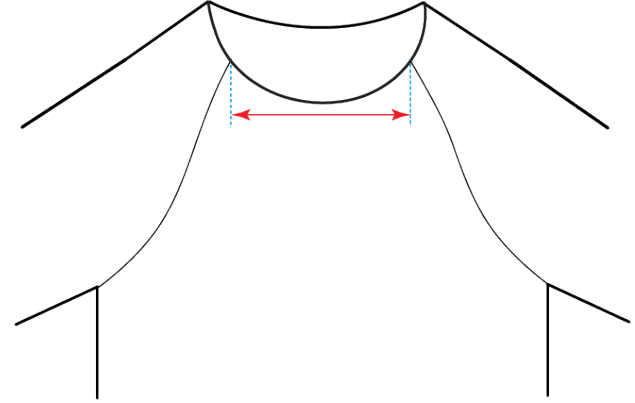
NK03	Neck Opening button to buttonhole	NK03-E	Neck Circumference Off Shoulder Extended	NK03-R	Neck Circumference Off Shoulder Relaxed
Measure straight through center of neck band from center of button to furthest tip of buttonhole (with zipper measure from tooth edge to tooth edge along neck seam).		Measure at top edge following curve of relaxed neckline.		Measure at top edge following curve of neckline, stretch until body fabric is flat, keep front and back edges even.	
					
NK04	Minimum Neck Stretch (Turtleneck/Mockneck)	NK05	Neck Trim Height	NR01	Front Raglan Neck Width-Seam to Seam
While stretching, measure neck opening from edge to edge.		Measure straight from neck seam to outer edge of trim.		Measure straight across from armhole seam to armhole seam at neck.	
					

HTM Guide

	Product Flex # :	144462	Name :	TD Template Product	Flex Spec ID :	91666
	Primary Catalog :		Seasonal Selling Quarter :		Season Name :	Fall 2014
Merchandiser :	PC - Chelsea Olm	Product Designer :		Tech Designer :		QA Technologist :
SFC :		Vendor :	GSO TBD	Sourcing :		GSO Tracking # :
Pack Number :		Size Definitions :		Womens Numeric---:6-24W, Womens Alpha---:S-3X, One Size---:One Size-One Size		Vendor Item # :

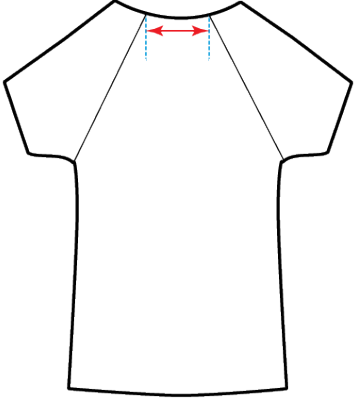
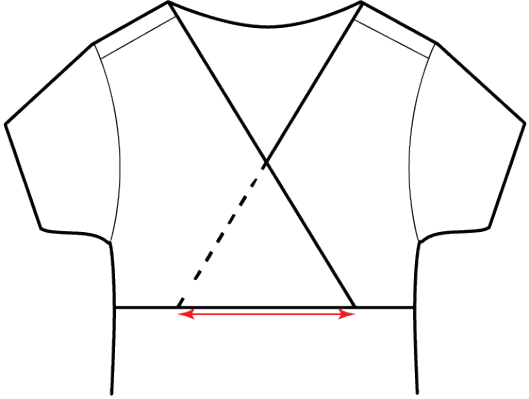
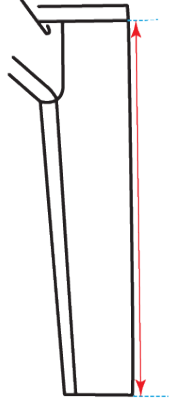
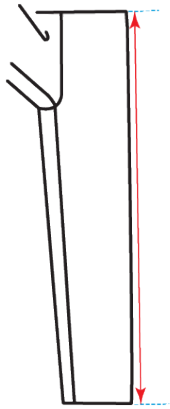
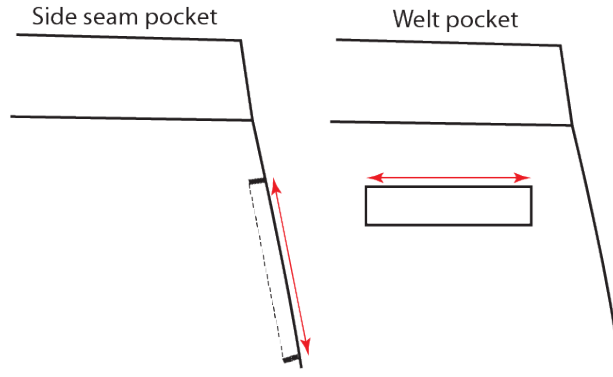
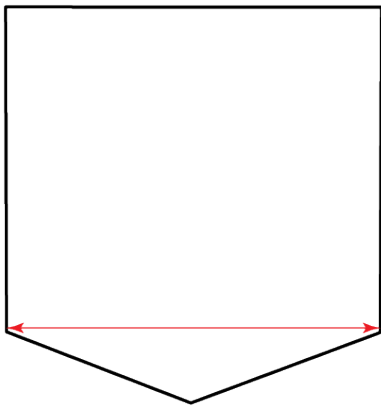
NR02	Back Raglan Neck Width-Seam to Seam	OL01	Overlap/Underlap Width	OT01	Outseam From Below Waistband
Measure straight across from armhole seam to armhole seam at neck.		Measure straight across garment from overlap point to underlap point of body.		Measure straight from waistband seam to leg opening at side seam.	
					
OT02	Outseam From Below Top Edge	PC01	Pocket Opening	PC02-B	Pocket Width at Bottom
Measure straight from top of garment to leg opening at side seam.		Measure functional opening following contour or straight (depending on type of pocket), from reinforcement or seam to reinforcement or seam.		Measure straight from edge to edge at Bottom of Pocket. For 5 point pocket measure at widest point.	
					

HTM Guide

	Product Flex # :	144462	Name :	TD Template Product	Flex Spec ID :	91666
	Primary Catalog :		Seasonal Selling Quarter :		Season Name :	Fall 2014
Merchandiser :	PC - Chelsea Olm	Product Designer :		Tech Designer :		QA Technologist :
SFC :		Vendor :	GSO TBD	Sourcing :		GSO Tracking # :
Pack Number :		Size Definitions :		Womens Numeric---:6-24W, Womens Alpha---:S-3X, One Size---:One Size-One Size		Vendor Item # :

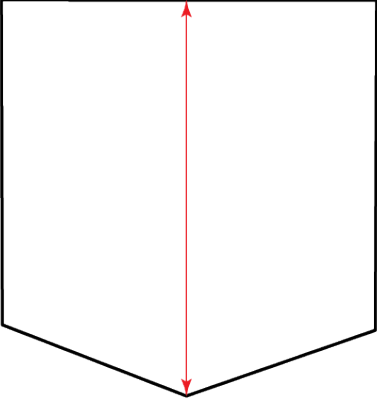
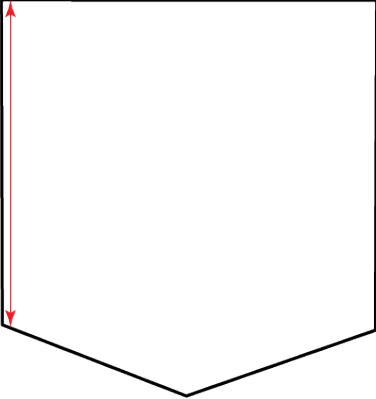
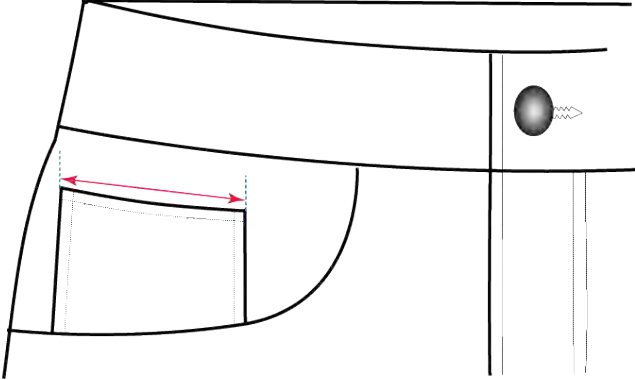
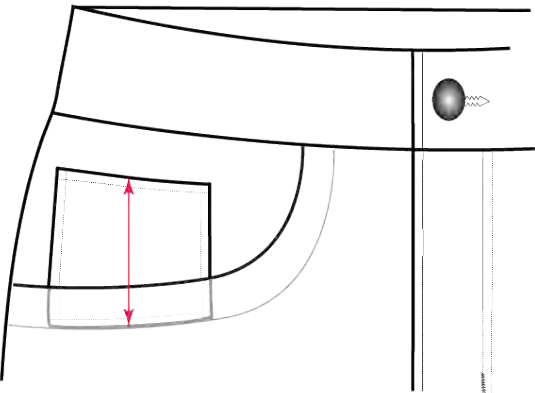
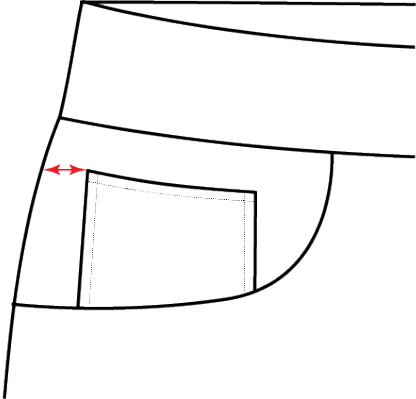
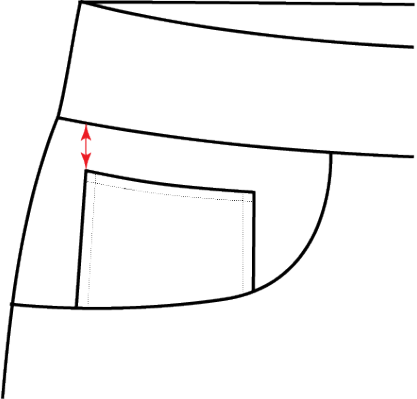
PC03-C	Pocket Height at Center of Pocket	PC03-S	Pocket Height at Side	PC04	Coin Pocket Width
Measure straight at center of pocket from top edge to bottom edge.		Measure straight at side of pocket from top edge to bottom edge.		Measure straight across width of coin pocket from edge to edge, along top edge.	
					
PC05	Coin Pocket Height	PC06	Coin Pocket Placement From Side Seam	PC07	Coin Pocket Placement Below WB
Measure straight across height of coin pocket from edge to seam (in the center of the coin pocket).		Measure straight the specified distance from the side seam horizontally to the side edge of the coin pocket.		Measure straight the specified distance from the waistband seam vertically to the top edge of the coin pocket.	
					

HTM Guide

	Product Flex # :	144462	Name :	TD Template Product	Flex Spec ID :	91666
	Primary Catalog :		Seasonal Selling Quarter :		Season Name :	Fall 2014
Merchandiser :	PC - Chelsea Olm	Product Designer :		Tech Designer :		QA Technologist :
SFC :		Vendor :	GSO TBD	Sourcing :		GSO Tracking # :
Pack Number :		Size Definitions :	Womens Numeric---:6-24W, Womens Alpha---:S-3X, One Size---:One Size-One Size	Vendor Item # :		

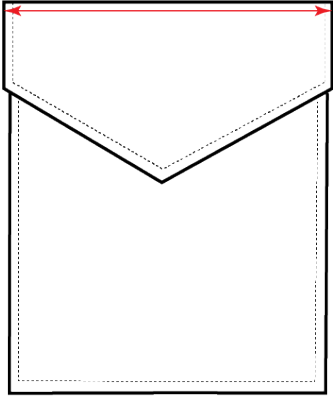
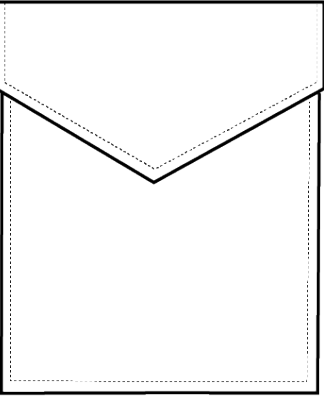
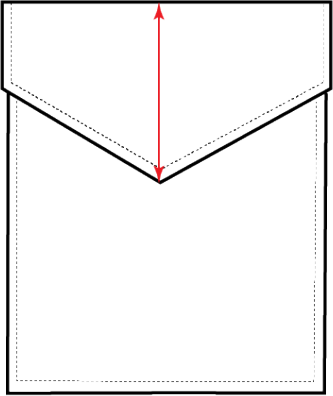
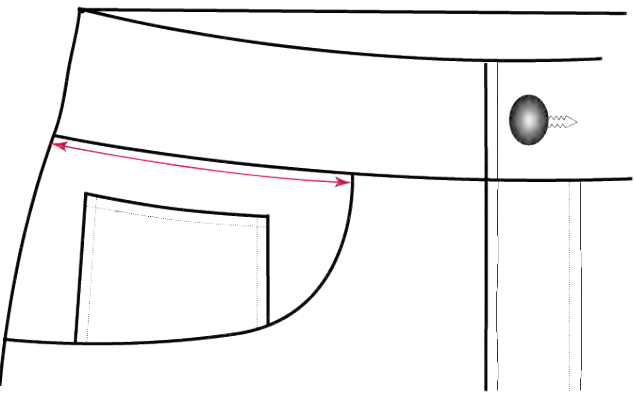
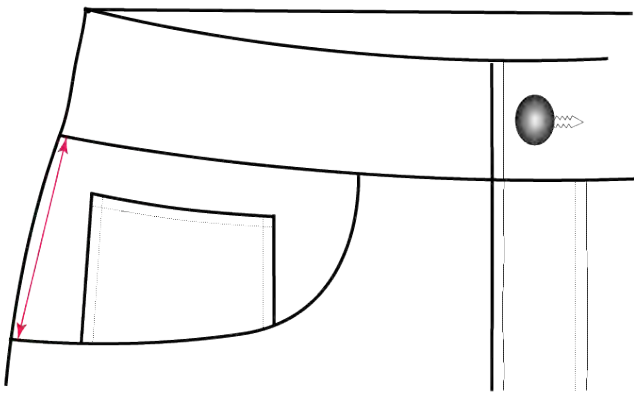
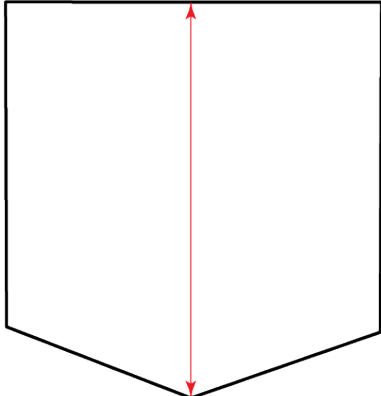
PC08	Pocket Flap Width at Top Edge	PC09	Pocket Flap Height @ Side	PC10	Pocket Flap Height @ Center
Measure across pocket flap from edge to edge.		Measure down at the side of pocket flap from top edge of to bottom edge.		Measure down at the center of the flap, from top edge of pocket flap to bottom edge.	
					
PC11	Front Pocket Placment From Side Seam	PC12	Front Pocket Placement Below Waistband	PC13	Pocket Height No Grade
Measure straight horizontally from the side seam to edge of front pocket at waistband seam.		Measure straight vertically from waistband seam to top edge of pocket at side seam.		Measure down the cetner of the pocket edge to edge.	
					

HTM Guide

	Product Flex # :	144462	Name :	TD Template Product	Flex Spec ID :	91666
	Primary Catalog :		Seasonal Selling Quarter :		Season Name :	Fall 2014
Merchandiser :	PC - Chelsea Olm	Product Designer :		Tech Designer :		QA Technologist :
SFC :		Vendor :	GSO TBD	Sourcing :		GSO Tracking # :
Pack Number :		Size Definitions :	Womens Numeric---:6-24W, Womens Alpha---:S-3X, One Size---:One Size-One Size	Vendor Item # :		

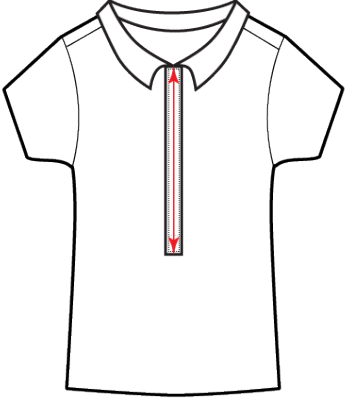
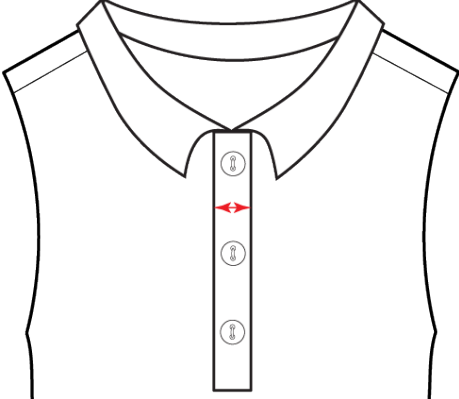
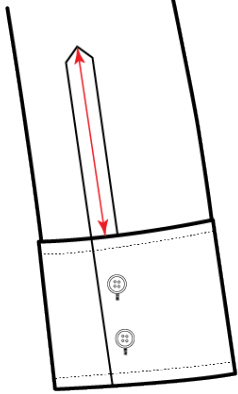
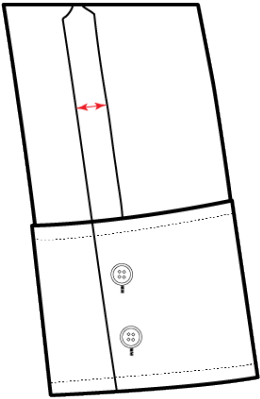
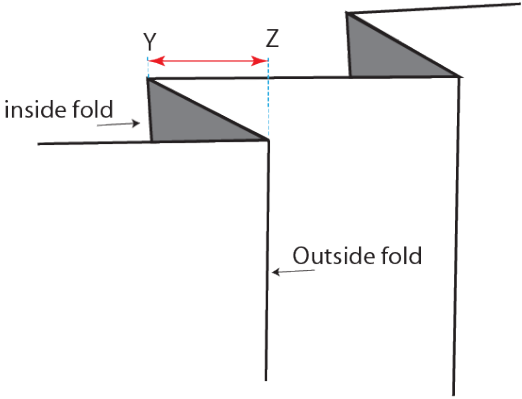
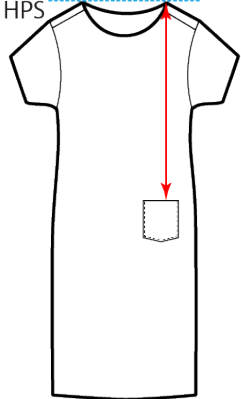
PK01	Placket Length	PK02	Placket Width	PK03	Sleeve Placket Length
Measure straight down from neck seam to bottom seam.		Measure straight across placket width from edge to edge or seam to edge.		Measure placket from seam to top edge of placket.	
					
PK04	Sleeve Placket Width	PL01	Pleat Depth	PP01	Hip Pocket Placement- Vertical
Measure width of placket from edge to seam.		Measure straight from fold (Z) to fold (Y) not doubled		Measure straight down the front of the garment from high point should (HPS) to the top edge of the pocket.	
					



HTM Guide



Product Flex # : 144462  
 Primary Catalog :

Name : TD Template Product  
 Seasonal Selling Quarter :

Flex Spec ID : 91666  
 Season Name : Fall 2014

Merchandiser : PC - Chelsea Olm  
 SFC :

Product Designer :  
 Vendor : GSO TBD

Tech Designer :  
 Sourcing :

QA Technologist :  
 GSO Tracking # :

Pack Number : Size Definitions :

Womens Numeric---:6-24W,  
 Womens Alpha---:S-3X, One  
 Size---:One Size-One Size

Vendor Item # :

<p>PP02 Chest Pocket Placement HPS- Vertical</p>	<p>PP03 Pocket Flap Placement HPS - Vertical</p>	<p>PP04 Pocket Placement Bottom Edge - Vertical</p>
<p>Measure straight down the front of the garment from high point should (HPS) to the top edge of the pocket.</p>	<p>Measure straight from high point should (HPS) to top of flap.</p>	<p>Measure straight up from the hemline to the bottom edge of the pocket.</p>
<p>PP05 Sleeve Pocket Placement from Shoulder Seam</p>	<p>PP06 Chest Pocket Placement from CF - Horizontal</p>	<p>PP07 Pocket Placement from SS - Horizontal</p>
<p>Measures straight from the shoulder seam to the top edge of the pocket.</p>	<p>Measure straight across from CF to the outside edge of the pocket.</p>	<p>Measure straight across from side seam to the outside edge of the pocket.</p>

HTM Guide

	Product Flex # :	144462	Name :	TD Template Product	Flex Spec ID :	91666
	Primary Catalog :		Seasonal Selling Quarter :		Season Name :	Fall 2014
Merchandiser :	PC - Chelsea Olm	Product Designer :		Tech Designer :		QA Technologist :
SFC :		Vendor :	GSO TBD	Sourcing :		GSO Tracking # :
Pack Number :		Size Definitions :	Womens Numeric---:6-24W, Womens Alpha---:S-3X, One Size---:One Size-One Size	Vendor Item # :		

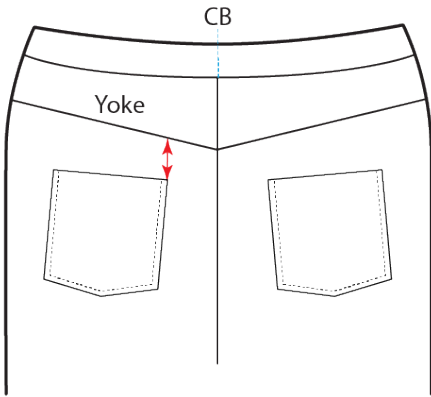
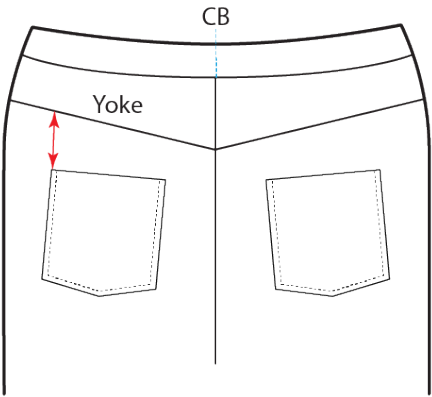
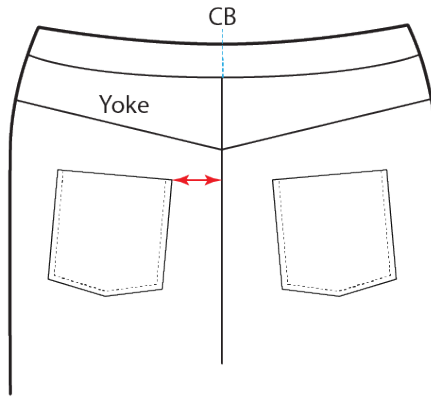
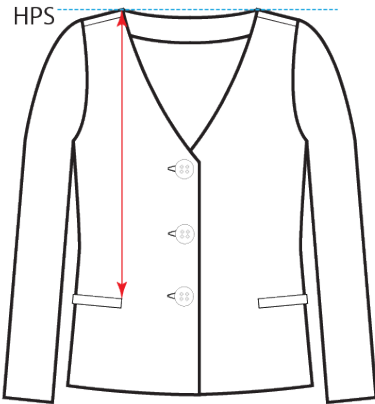
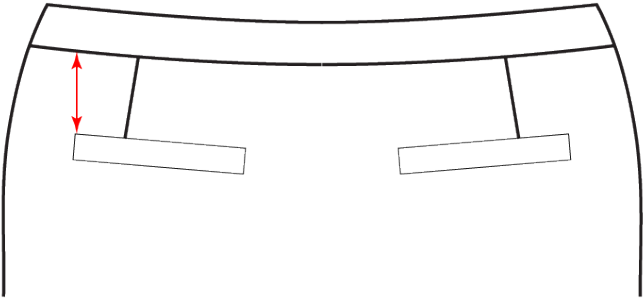
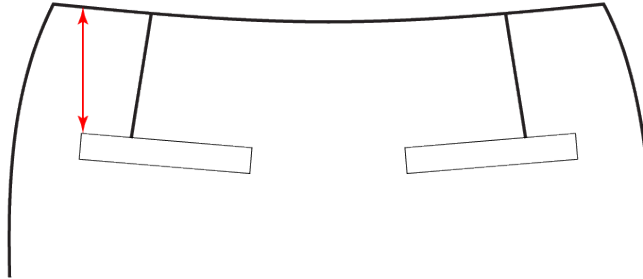
PP08	Pocket Placement Below Yoke Seam at CB	PP09	Pocket Placement Below Yoke at Side Seam	PP10	Pocket Placement From CB at Top of Pocket
Measure down from the yoke seam to the top edge of the pocket. Measurement is taken at edge closest to CB Seam.		Measure down from the yoke seam to the top edge of the pocket. Measurement is taken at edge closest to Side Seam.		Measure straight across from top edge of pocket to center CB Seam/ Center of 2N Stitching.	
					
PP11	Pocket Placement from HPS to Waist	PP12	Pocket Placement from Below Waist Seam	PP13	Pocket Placement from Below top Of Waist
Measure straight the specified distance from high point shoulder (HPS) vertically to top edge of pocket.		Measure the specified distance straight frm WB seam top of pocket		Measure the specified distance straight frm top of waist to top of pocket	
					

HTM Guide

	Product Flex # :	144462	Name :	TD Template Product	Flex Spec ID :	91666
	Primary Catalog :		Seasonal Selling Quarter :		Season Name :	Fall 2014
Merchandiser :	PC - Chelsea Olm	Product Designer :	Tech Designer :	QA Technologist :		
SFC :		Vendor :	GSO TBD	Sourcing :	GSO Tracking # :	
Pack Number :		Size Definitions :	Womens Numeric---:6-24W, Womens Alpha---:S-3X, One Size---:One Size-One Size	Vendor Item # :		

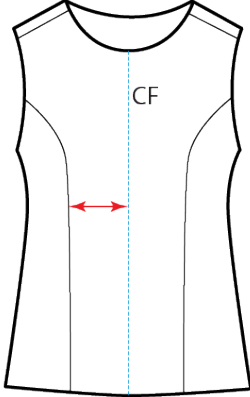
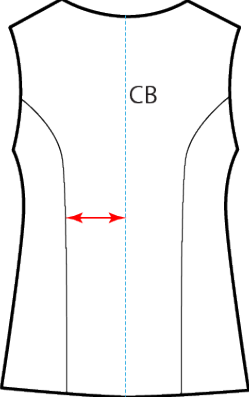
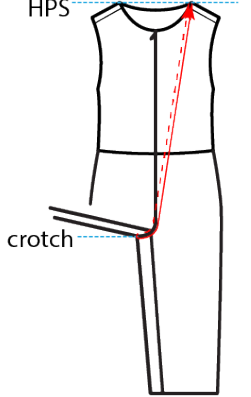
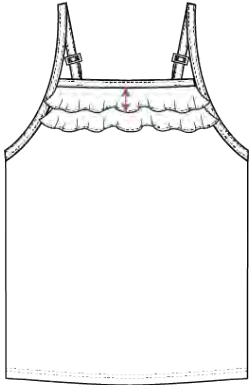
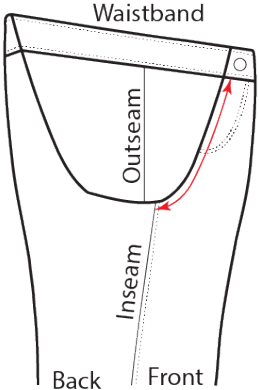
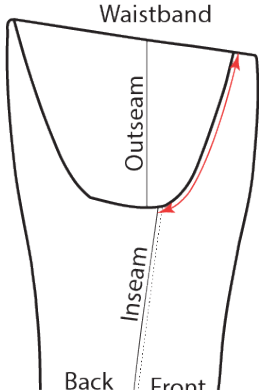
PS01	Princess Seam Placement from CF Waist	PS02	Princess Seam Placement from CB Waist	QO01	Total Vertical Trunk (circumference)
Measures straight across from CF to princess seam. Measurement should be taken at specified waist placement.		Measures straight across from CB to princess seam. Measurement should be taken at specified waist placement.		Measure down from HPS to crotch at front panel, pivot to measure back panel from crotch to HPS.	
					
RH01	Ruffle Height	RS01	Front Rise from Below WB Seam (curved)	RS01-T	Front Rise from Top Edge (curved)
Measure straight from seam of ruffle to edge of ruffle.		Measure pant following natural curve (without stretching) from waistband seam to crotch seam.		Measure pant following natural curve (without stretching) from top edge of waist to crotch seam.	
					

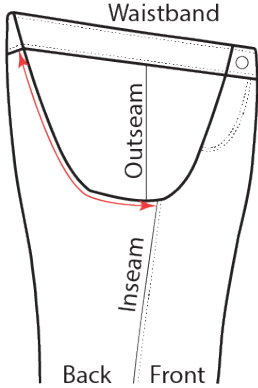
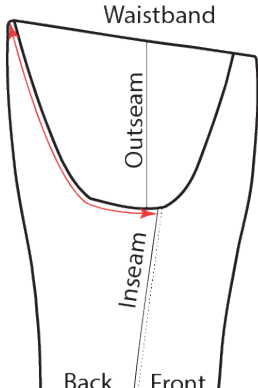
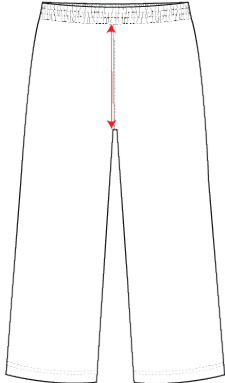
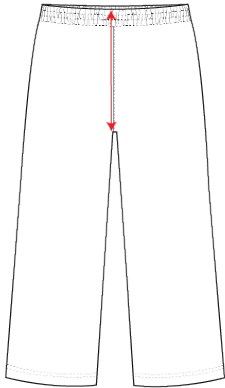
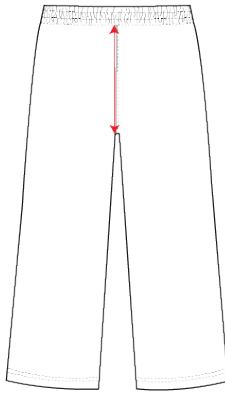
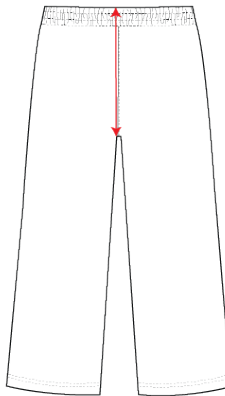

HTM Guide

	Product Flex # :	144462	Name :	TD Template Product	Flex Spec ID :	91666
	Primary Catalog :		Seasonal Selling Quarter :		Season Name :	Fall 2014
Merchandiser :	PC - Chelsea Olm	Product Designer :		Tech Designer :		QA Technologist :
SFC :		Vendor :	GSO TBD	Sourcing :		GSO Tracking # :
Pack Number :		Size Definitions :	Womens Numeric---:6-24W, Womens Alpha---:S-3X, One Size---:One Size-One Size	Vendor Item # :		

RS02	Back Rise from Below WB Seam(Curved)	RS02-T	Back Rise from Top Edge (Curved)	RS03	Front Rise From Below WB Seam (straight)
Measure pant following natural curve (without stretching) from waistband seam to crotch seam.		Measure pant following natural curve (without stretching) from top edge of waist to crotch seam.		Measure pant following natural curve (without stretching) from waistband seam to crotch seam.	
					
RS03-T	Front Rise From Top Edge (straight)	RS04	Back Rise From Below WB Seam (straight)	RS04-T	Back Rise From Top Edge (straight)
Measure pant following natural curve (without stretching) from top edge of waist to crotch seam.		Measure pant following natural curve (without stretching) from waistband seam to crotch seam.		Measure pant following natural curve (without stretching) from top edge of waist to crotch seam.	
					

HTM Guide

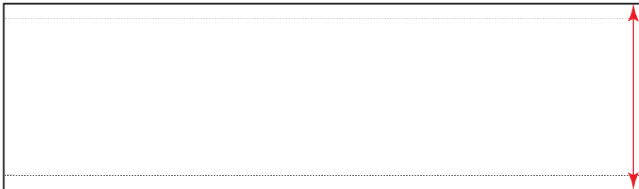
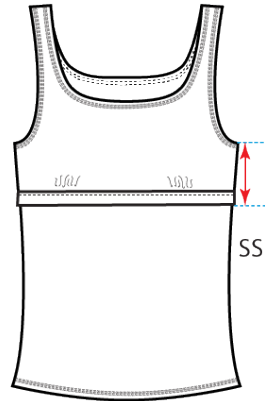
	Product Flex # :	144462	Name :	TD Template Product	Flex Spec ID :	91666
	Primary Catalog :		Seasonal Selling Quarter :		Season Name :	Fall 2014
Merchandiser :	PC - Chelsea Olm	Product Designer :		Tech Designer :		QA Technologist :
SFC :		Vendor :	GSO TBD	Sourcing :		GSO Tracking # :
Pack Number :		Size Definitions :	Womens Numeric---:6-24W, Womens Alpha---:S-3X, One Size---:One Size-One Size	Vendor Item # :		

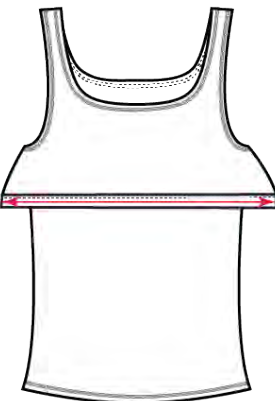
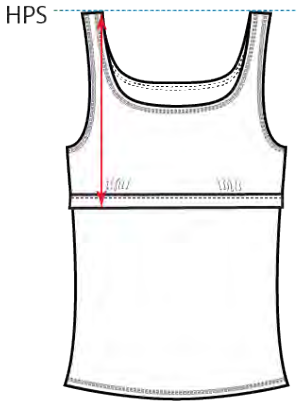
SC01	Scarf Length	SC02	Scarf Width	SF01	Shelf Bra Height @SS
Measure straight along the length of Scarf, from edge to edge		Measure straight along the width of Scarf, from edge to edge		Measure shelf bra height along side seam (SS), include elastic edge.	
					
SF02	Shelf Bra Opening - Relaxed	SF03	Shelf BraOpening- Extended	SF04	Shelf Bra Height HPS to Bottom Edge
Measure along bottom of elastic band, relaxed. (circumference)		Stretch elastic along bottom edge until fabric is flat. Do not over extend. Measure along bottom of elastic band, extended.(circumference)		Measure shelf bra height at High Point Shoulder (HPS) straight down to bottom edge of elastic.	
					

HTM Guide

	Product Flex # :	144462	Name :	TD Template Product	Flex Spec ID :	91666
	Primary Catalog :		Seasonal Selling Quarter :		Season Name :	Fall 2014
Merchandise :	PC - Chelsea Olm	Product Designer :		Tech Designer :		QA Technologist :
SFC :		Vendor :	GSO TBD	Sourcing :		GSO Tracking # :
Pack Number :		Size Definitions :	Womens Numeric---:6-24W, Womens Alpha---:S-3X, One Size---:One Size-One Size	Vendor Item # :		

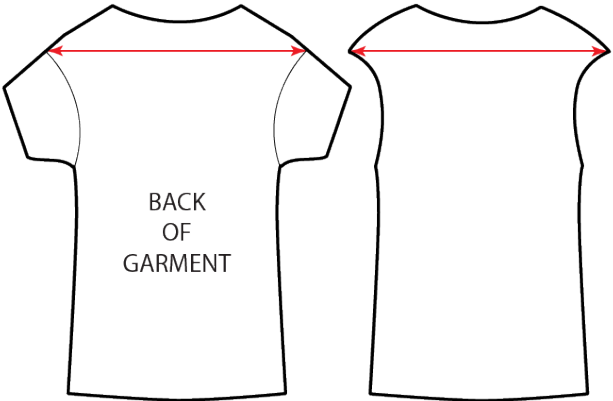
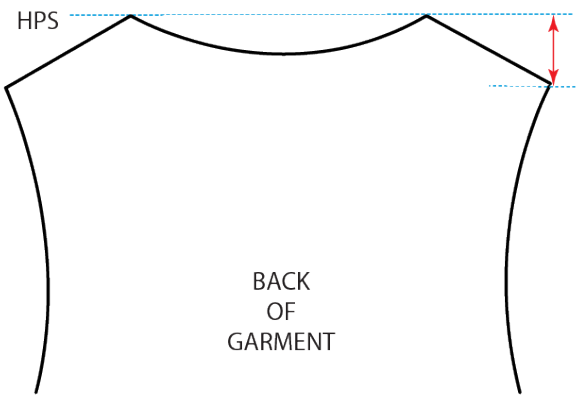
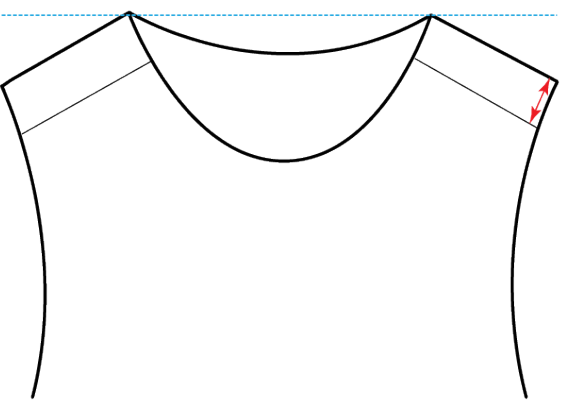
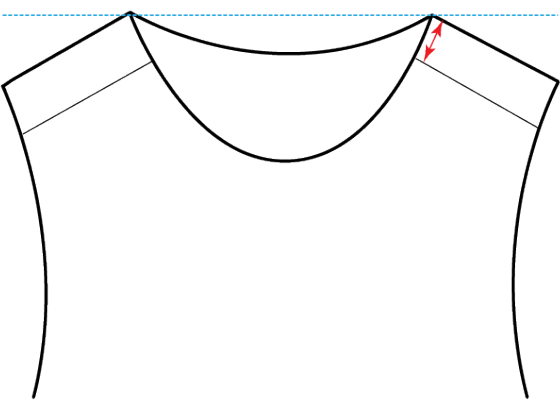
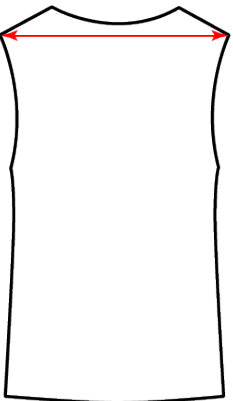
SH01	Across Shoulder Set-in	SH01-D	Across Shoulder Dropped-SLEEVE LENGH GRADE 0"	SH02	Shoulder Slope
Measure on the back of garment straight across shoulder, seam to seam.		Measure on the back of garment straight across shoulder, seam to seam (edge to edge if sleeveless).		On the back of the garment, measure perpendicular from high point shoulder (HPS) imaginary line straight down to low point of shoulder seam or edge.	
 <p>BACK OF GARMENT</p>		 <p>BACK OF GARMENT</p>		 <p>HPS</p> <p>BACK OF GARMENT</p>	
SH03-A	Forward Shoulder Seam Width at Armhole	SH03-H	Forward Shoulder Seam Width at HPS	SH04-E	Across Shoulder - Sleeveless - Edge to Edge
Measure straight down from folded edge of garment to the forward shoulder seam.		Measure straight down from HPS of garment to the forward shoulder seam.		On the back of garment, measure straight across shoulder edge to edge.	
 <p>HPS</p>		 <p>HPS</p>		 <p>BACK OF GARMENT</p>	

HTM Guide

	Product Flex # :	144462	Name :	TD Template Product	Flex Spec ID :	91666
	Primary Catalog :		Seasonal Selling Quarter :		Season Name :	Fall 2014
Merchandiser :	PC - Chelsea Olm	Product Designer :		Tech Designer :		QA Technologist :
SFC :		Vendor :	GSO TBD	Sourcing :		GSO Tracking # :
Pack Number :		Size Definitions :		Womens Numeric---:6-24W, Womens Alpha---:S-3X, One Size---:One Size-One Size		Vendor Item # :

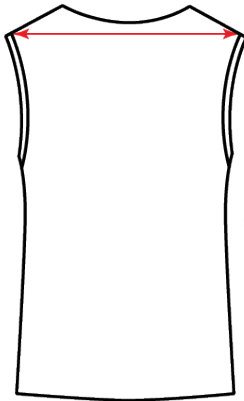
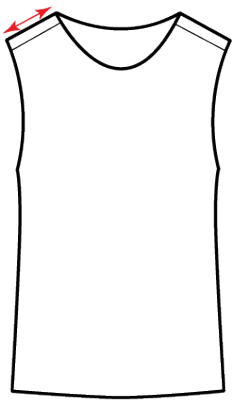
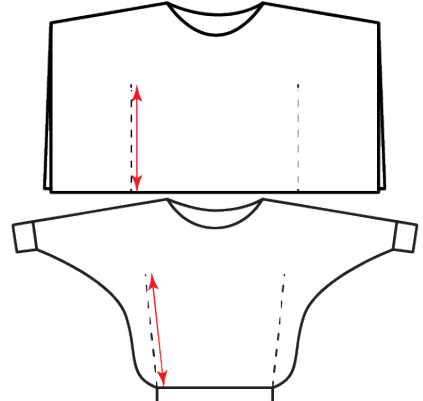
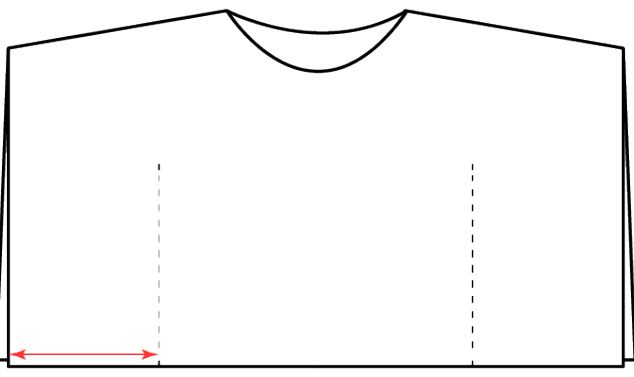
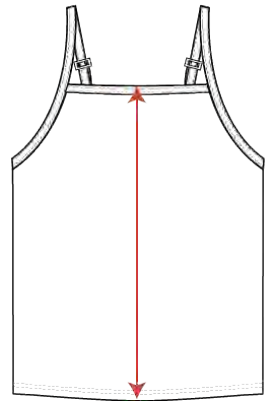
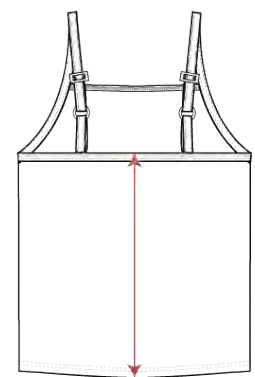
SH04-S	Across Shoulder - Sleeveless - Seam to Seam	SH07	Single Shoulder	SL01	Stitch Line Length
On the back of garment, measure straight across shoulder seam to seam.		Measure along shoulder seam (seam to seam) from HPS at neck seam to armhole seam, measure edge to edge if sleeveless		Measure straight from top of stitch line to bottom of stitch line.	
 <p>BACK OF GARMENT</p>					
SL02	Stitch Line Placement @ Sweep	SM01	Swim Body Length at CF	SM02	SWIM CB Body Length
Measure straight across from stitch line to edge at sweep.		Measure straight from top edge of bodice to hem edge at CF		Measure straight from top edge of bodice to hem edge at CB	
					

HTM Guide

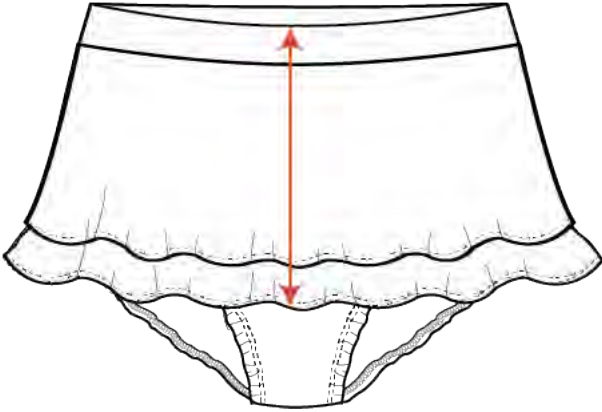
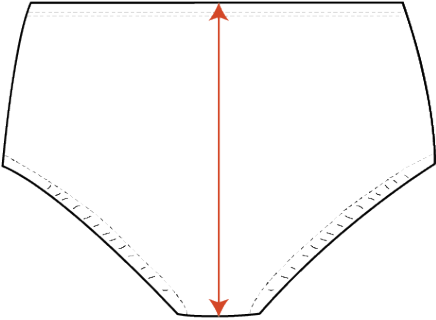
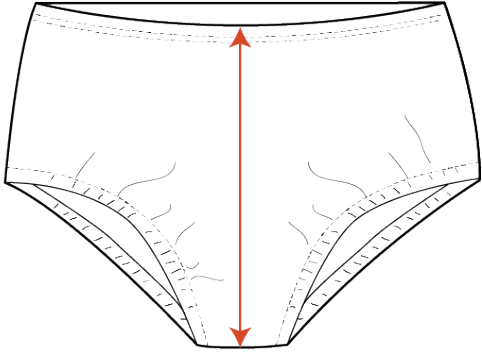
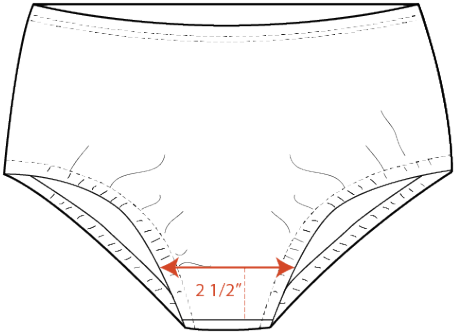
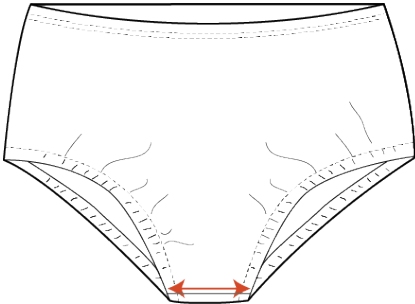
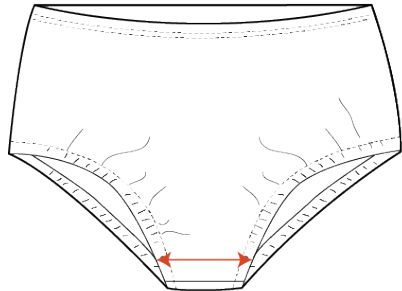

	Product Flex # :	144462	Name :	TD Template Product	Flex Spec ID :	91666
	Primary Catalog :		Seasonal Selling Quarter :		Season Name :	Fall 2014
Merchandiser :	PC - Chelsea Olm	Product Designer :		Tech Designer :		QA Technologist :
SFC :		Vendor :	GSO TBD	Sourcing :		GSO Tracking # :
Pack Number :		Size Definitions :	Womens Numeric---:6-24W, Womens Alpha---:S-3X, One Size---:One Size-One Size	Vendor Item # :		

SM03	Swim Skirt Length	SM04	Swim CB Length	SM05	Swim CF Length
Measures Straight from top edge of waist to bottom edge of skirt.		Measure straight from top edge of waist to crotch seam at CF		Measure straight from top edge of waist to crotch seam at CB	
					
SM06	Swim Crotch Width at 2 1/2" up from seam	SM07	Swim Crotch Width at seam	SM08	Swim Crotch Width at smallest point
Measure straight from edge to edge at 2 1/2" up from crotch seam		Measure straight from edge to edge at crotch seam		Find narrowest part up from the crotch seam, Measure straight from edge to edge.	
					

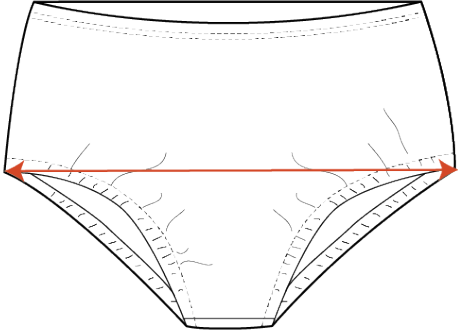
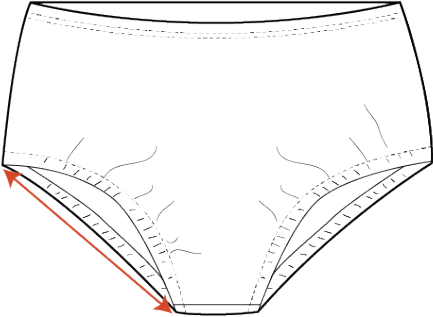
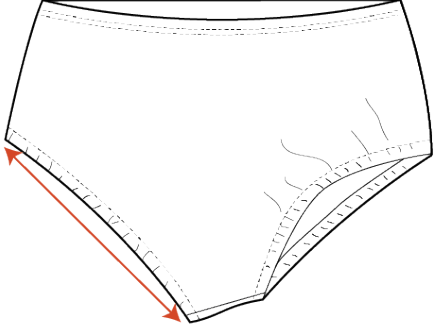
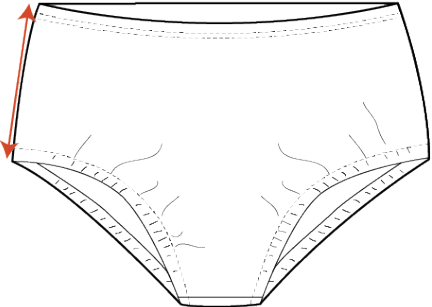

HTM Guide

	Product Flex # :	144462	Name :	TD Template Product	Flex Spec ID :	91666
	Primary Catalog :		Seasonal Selling Quarter :		Season Name :	Fall 2014
Merchandise :	PC - Chelsea Olm	Product Designer :		Tech Designer :		QA Technologist :
SFC :		Vendor :	GSO TBD	Sourcing :		GSO Tracking # :
Pack Number :		Size Definitions :	Womens Numeric---:6-24W, Womens Alpha---:S-3X, One Size---:One Size-One Size	Vendor Item # :		

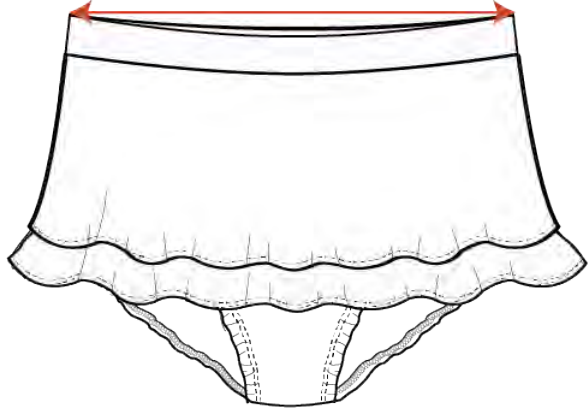
SM09	Swim Hip Seat Width at Leg Opening	SM10	Swim Leg opening Relaxed	SM11	Swim Leg Opening Extended
Measure straight from edge to edge at lower corner of leg opening.		Align front and back leg opening, measures straight from edge to edge.		Align front and back leg opening, stretch leg opening, measures straight from edge to edge.	
					
SM12	Swim Sideseam Length	SM13	Swim Waist Relaxed	SM14	Swim Waist Extended
Measure straight from top edge of waist to leg opening along sideseam		Measures Straight from edge to edge at waist opening.		Measures Straight from edge to edge at waist opening, with waist fully extended.	
					

HTM Guide

	Product Flex # :	144462	Name :	TD Template Product	Flex Spec ID :	91666
	Primary Catalog :		Seasonal Selling Quarter :		Season Name :	Fall 2014
Merchandiser :	PC - Chelsea Olm	Product Designer :		Tech Designer :		QA Technologist :
SFC :		Vendor :	GSO TBD	Sourcing :		GSO Tracking # :
Pack Number :		Size Definitions :	Womens Numeric---:6-24W, Womens Alpha---:S-3X, One Size---:One Size-One Size	Vendor Item # :		

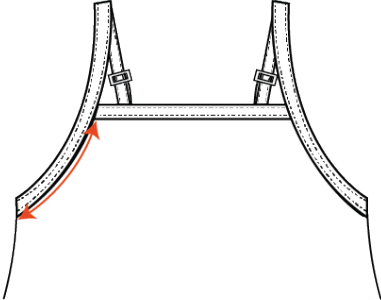
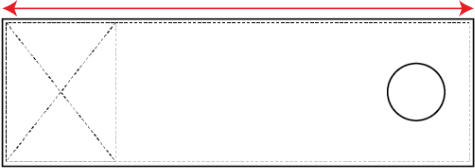
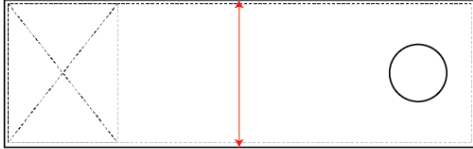
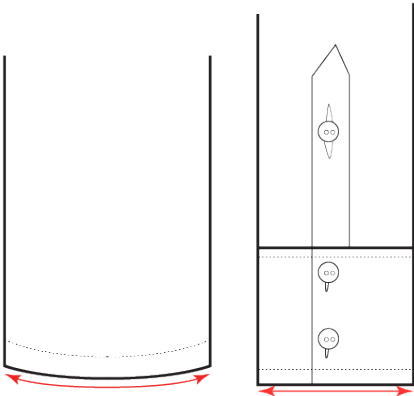
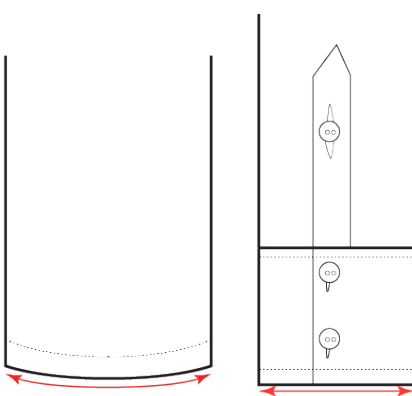
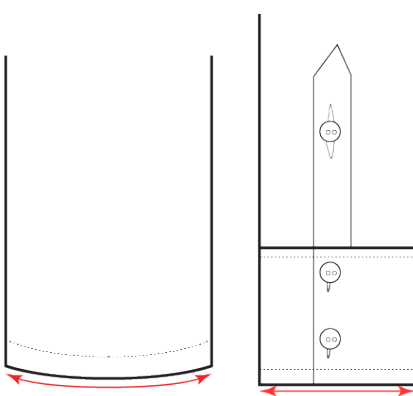
SM15	Front Armhole Curve along seam	SN01	Snap Tab Length	SN02	Snap Tab Width
Measure along armhole curve at seam from front neck seam to armhole seam.		Measure straight from snap tab seam to opposite edge of snap tab.		Measure straight along the width of snap tab, edge to edge.	
					
SO01	Sleeve Opening- Long	SO02	Sleeve Opening- Elbow	SO03	Sleeve Opening- Short
Measure straight across sleeve at BOTTOM opening from outside edge to outside edge. If shaped, measure along curve.		Measure straight across sleeve at BOTTOM opening from outside edge to outside edge. If shaped, measure along curve.		Measure straight across sleeve at BOTTOM opening from outside edge to outside edge. If shaped, measure along curve.	
					

HTM Guide

	Product Flex # :	144462	Name :	TD Template Product	Flex Spec ID :	91666
	Primary Catalog :		Seasonal Selling Quarter :		Season Name :	Fall 2014
Merchandiser :	PC - Chelsea Olm	Product Designer :		Tech Designer :		QA Technologist :
SFC :		Vendor :	GSO TBD	Sourcing :		GSO Tracking # :
Pack Number :		Size Definitions :	Womens Numeric---:6-24W, Womens Alpha---:S-3X, One Size---:One Size-One Size	Vendor Item # :		

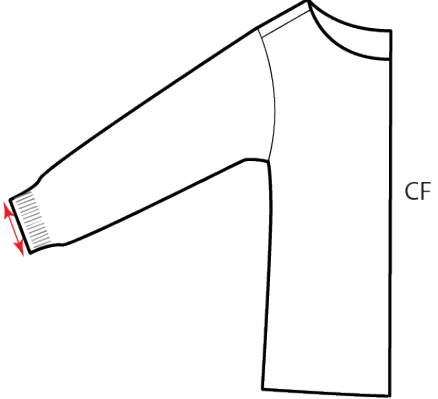
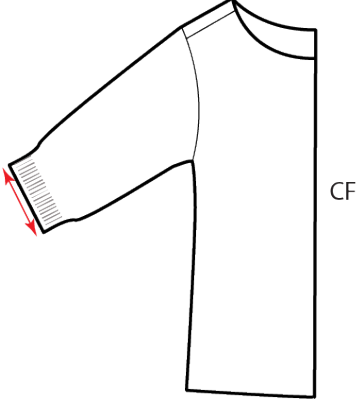
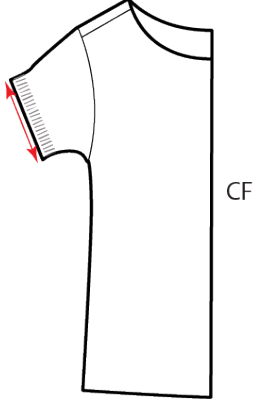
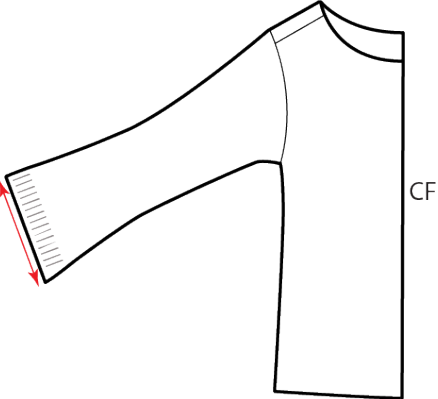
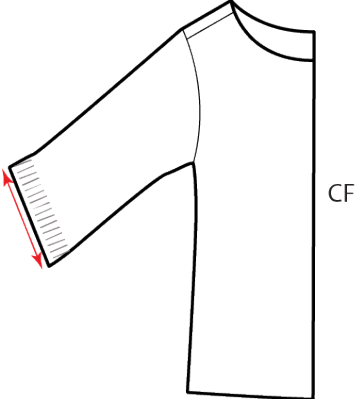
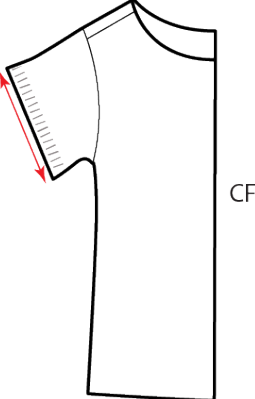
SO04	Sleeve Opening - Relaxed (long)	SO05	Sleeve Opening - Relaxed (elbow)	SO06	Sleeve Opening - Relaxed (short)
Measure straight across sleeve at BOTTOM opening from outside edge to outside edge RELAXED.		Measure straight across sleeve at BOTTOM opening from outside edge to outside edge RELAXED.		Measure straight across sleeve at BOTTOM opening from outside edge to outside edge RELAXED.	
					
SO07	Sleeve Opening - Extended (long)	SO08	Sleeve Opening - Extended (elbow)	SO09	Sleeve Opening - Extended (short)
Measure along BOTTOM of sleeve opening, extending until fabric is flat. DO NOT OVER EXTEND MEASUREMENT.		Measure along BOTTOM of sleeve opening, extending until fabric is flat. DO NOT OVER EXTEND MEASUREMENT.		Measure along BOTTOM of sleeve opening, extending until fabric is flat. DO NOT OVER EXTEND MEASUREMENT.	
					

HTM Guide

	Product Flex # :	144462	Name :	TD Template Product	Flex Spec ID :	91666
	Primary Catalog :		Seasonal Selling Quarter :		Season Name :	Fall 2014
Merchandiser :	PC - Chelsea Olm	Product Designer :		Tech Designer :		QA Technologist :
SFC :		Vendor :	GSO TBD	Sourcing :		GSO Tracking # :
Pack Number :		Size Definitions :	Womens Numeric---:6-24W, Womens Alpha---:S-3X, One Size---:One Size-One Size	Vendor Item # :		

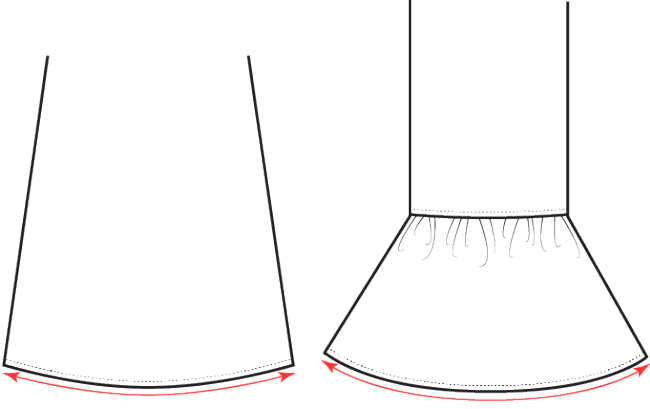
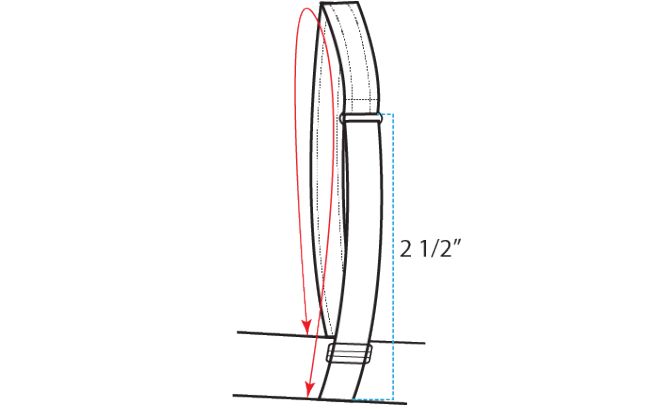
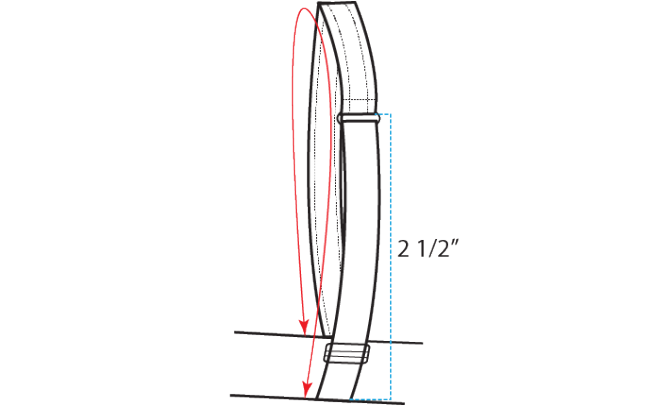
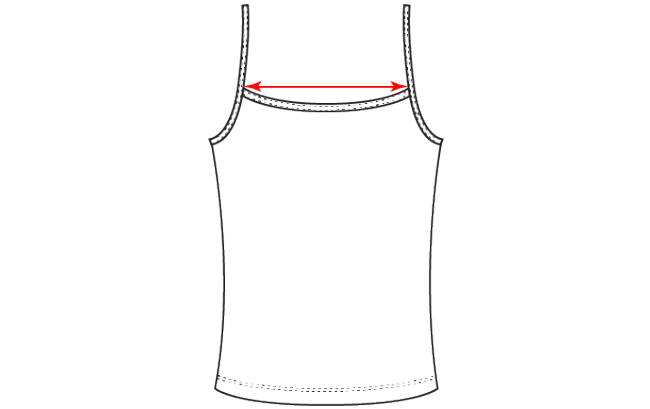
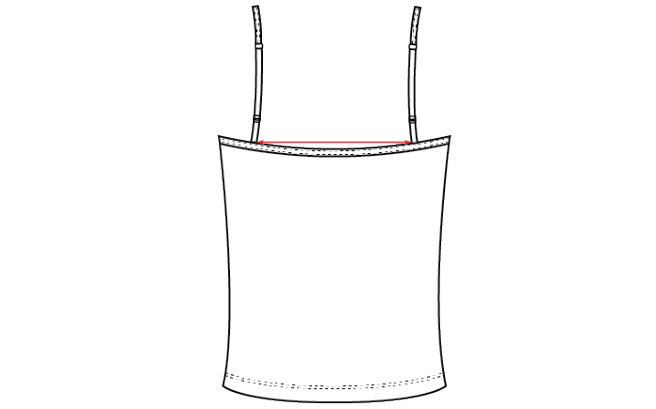
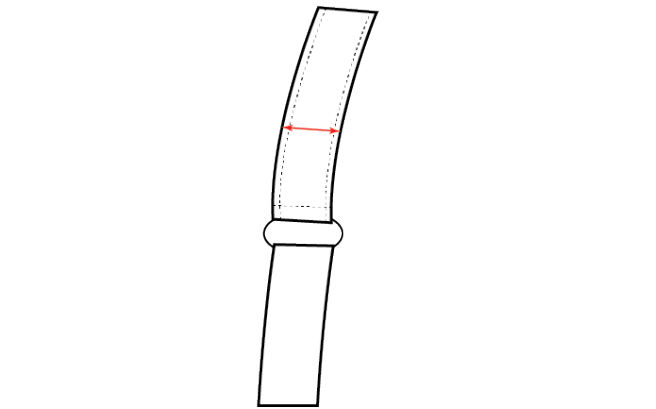
SO10	Sleeve Opening – Large Opening Along Edge	ST01	Strap Length Short (10 1/2" or Shorter)	ST02	Strap Length Long (10 1/2" or Longer)
Measure following curve along sleeve opening from outside edge to outside edge.		Measure from edge to edge or seam to seam at center of strap. If an adjuster is present, straps must be adjusted 2 1/2" total from strap join seam to top of hardware (including all hardware).		Measure from edge to edge or seam to seam at center of strap. If an adjuster is present, straps must be adjusted 2 1/2" total from strap join seam to top of hardware (including all hardware).	
					
ST03	Front Strap Spread- Inside Edge to Inside Edge	ST04	Back Strap Spread- Inside Edge to Inside Edge	ST05	Strap Width- Edge to Edge
Measure straight across from inside strap edge to inside strap edge.		Measure straight across from inside strap edge to inside strap edge.		Measure straight across edge to edge.	
					

HTM Guide

	Product Flex # :	144462	Name :	TD Template Product	Flex Spec ID :	91666
	Primary Catalog :		Seasonal Selling Quarter :		Season Name :	Fall 2014
Merchandise :	PC - Chelsea Olm	Product Designer :		Tech Designer :		QA Technologist :
SFC :		Vendor :	GSO TBD	Sourcing :		GSO Tracking # :
Pack Number :		Size Definitions :		Womens Numeric---:6-24W, Womens Alpha---:S-3X, One Size---:One Size-One Size		Vendor Item # :

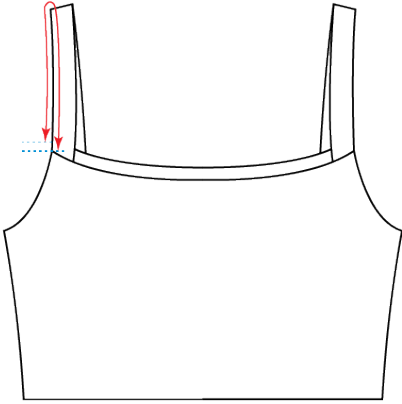
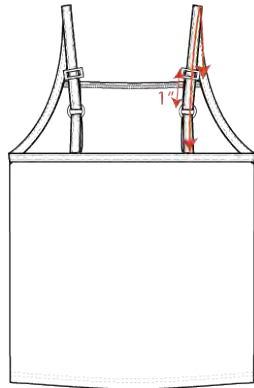
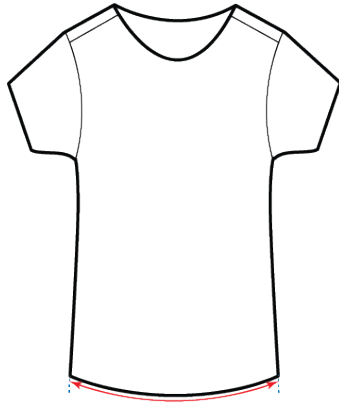
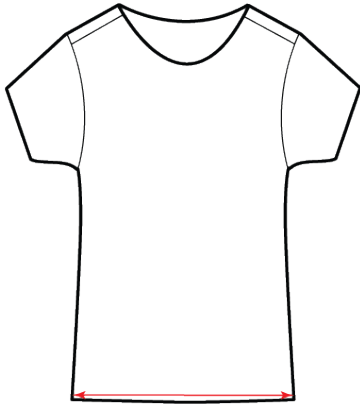
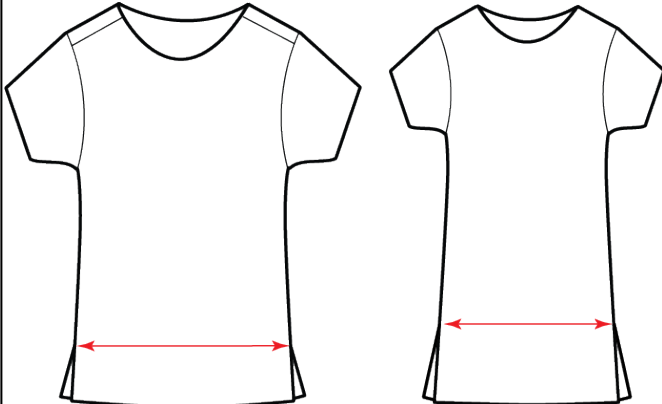
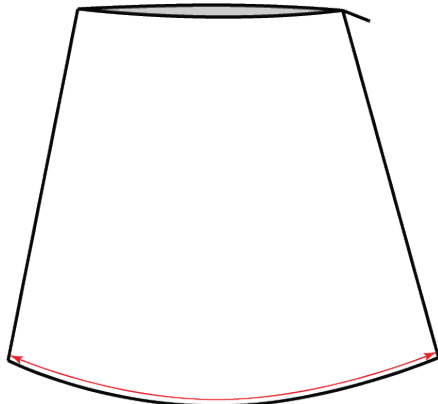
ST06	Strap Length Non-Adjustable	ST07	Childrens Strap Length (include 1" adjustability)	SW01-C	Sweep- Along Curve (Top)
Measure from edge to edge or seam to seam		Measure along strap from front seam to back seam, including adjustability		Measure sweep from edge to edge, following curve of bottom hemline.	
					
SW01-S	Sweep- Straight Across (Top)	SW02	Sweep- Straight Across at Top of Slit	SW03-C	Sweep- Along Curve (Bottom)
Measure sweep straight across bottom from edge to edge (circum).		Measure straight at top of slits from edge to edge (circum).		Measure garment fully extended along curve of hemline.	
					

HTM Guide

	Product Flex # :	144462	Name :	TD Template Product	Flex Spec ID :	91666
	Primary Catalog :		Seasonal Selling Quarter :		Season Name :	Fall 2014
Merchandiser :	PC - Chelsea Olm	Product Designer :		Tech Designer :		QA Technologist :
SFC :		Vendor :	GSO TBD	Sourcing :		GSO Tracking # :
Pack Number :		Size Definitions :	Womens Numeric---:6-24W, Womens Alpha---:S-3X, One Size---:One Size-One Size	Vendor Item # :		

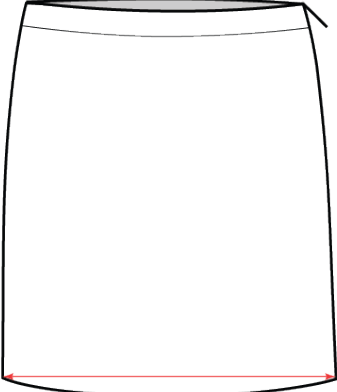
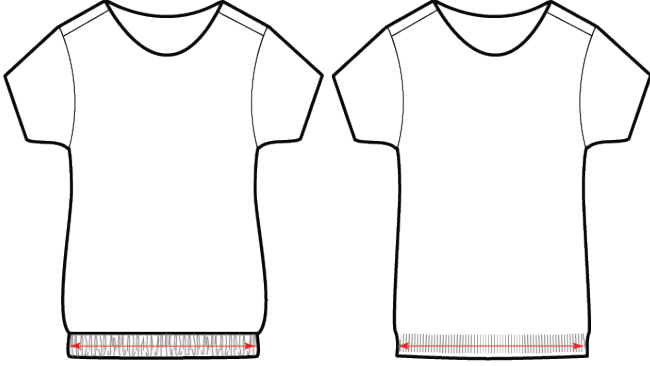
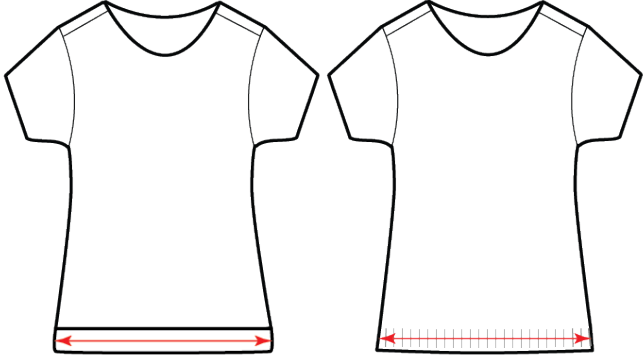
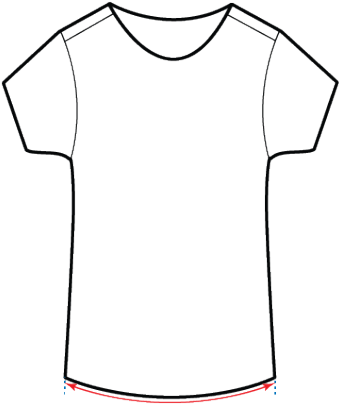
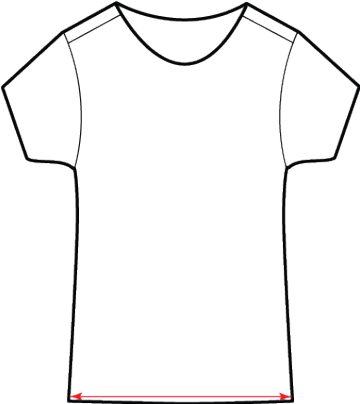
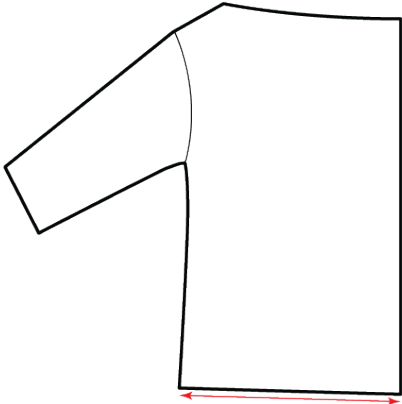
SW03-S	Sweep- Straight Across (Bottom)	SW04	Sweep Relaxed (Center of Ribbing)	SW05	Sweep Extended (Center of Ribbing)
Measure straight across bottom from edge to edge (circum).		Measure straight across from edge to edge in the center of relaxed band or rib. (circumference)		Measure straight across from edge to edge in the center of band or rib, extending until body fabric is flat, keeping front and back edges even. Do Not Over Extend Garment. (circumference)	
					
SW06-C	Sweep Along Curve- Flat (TOP)	SW06-S	Sweep Straight Across - Flat (Top)	SW07	Flyaway Front Panel Width @ Sweep
Measure garment fully extended along curve of hemline.		Measure straight across bottom from edge to edge (flat).		Measure straight across the garment from side seam to center front edge at the sweep.	
					

HTM Guide



Product Flex # : 144462  
 Primary Catalog :

Name : TD Template Product  
 Seasonal Selling Quarter :

Flex Spec ID : 91666  
 Season Name : Fall 2014

Merchandiser : PC - Chelsea Olm  
 SFC :

Product Designer :  
 Vendor : GSO TBD

Tech Designer :  
 Sourcing :

QA Technologist :  
 GSO Tracking # :

Pack Number : Size Definitions :

Womens Numeric---:6-24W,  
 Womens Alpha---:S-3X, One  
 Size---:One Size-One Size

Vendor Item # :

SW08	Back Sweep- Straight Across (Full Grade)	SW09-C	Back Sweep Along Curve (1/2 Grade)	SW09-S	Back Sweep Straight Across (1/2 Grade)
Measure straight across bottom from edge to edge (circum).		Measure across bottom seam to seam following curve.		Measure straight across bottom from seam to seam.	
SW10	Sweep Straight Hankie Hem W/Vents (1/2 Grade)	SW11	Sweep Straight Hankie Hem (no vents)	TH01	Thigh 1" Below Crotch
Measure straight across at top of vents from edge to edge (flat).		Measure straight across bottom, at longest point, edge to edge (circum).		With leg creased along out seam, measure 1" below crotch seam straight across from folded edge to edge.	

HTM Guide

	Product Flex # :	144462	Name :	TD Template Product	Flex Spec ID :	91666
	Primary Catalog :		Seasonal Selling Quarter :		Season Name :	Fall 2014
Merchandiser :	PC - Chelsea Olm	Product Designer :		Tech Designer :		QA Technologist :
SFC :		Vendor :	GSO TBD	Sourcing :		GSO Tracking # :
Pack Number :		Size Definitions :		Womens Numeric---:6-24W, Womens Alpha---:S-3X, One Size---:One Size-One Size		Vendor Item # :

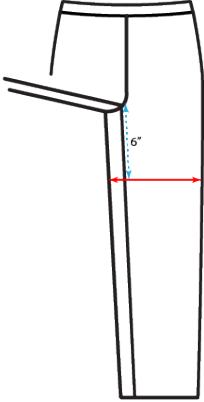
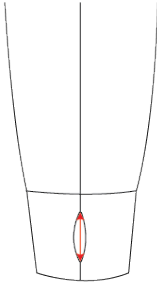
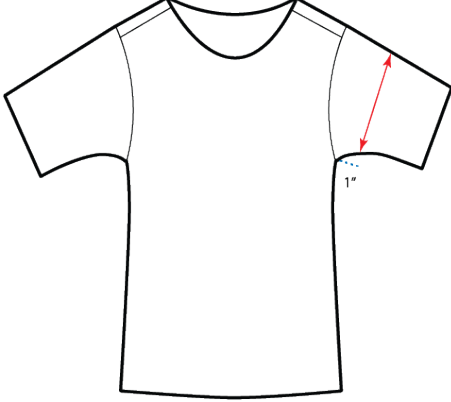
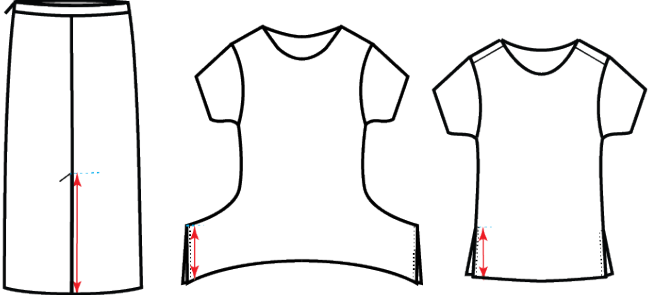
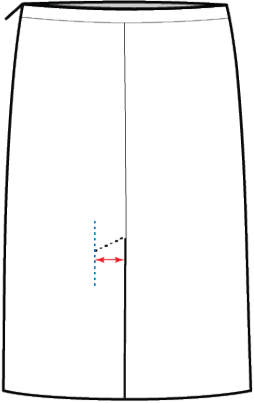
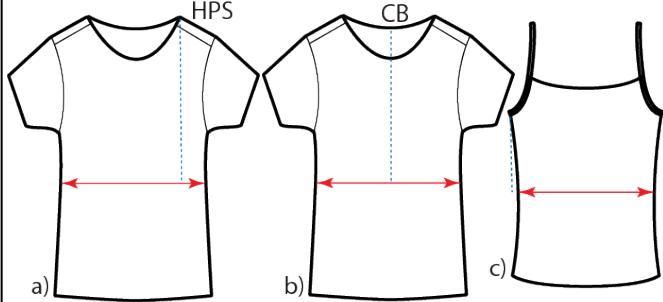
TH02	Mid Thigh 6" Down From Crotch	TL01	Thumb Hole Length	UA01	Upperarm 1" below armhole
With leg creased along out seam, measure 6" below crotch point straight across from edge to edge.		Measure from edge to edge of thumb hole opening		Measure straight 1" down from armhole seam straight across from edge to edge (circum).	
					
VH01	Vent/Slit Height	VW01	Vent Overlap Width	WA01	Waist @ Spec Location
Measure vent/slit from the bottom edge to the top of the slit/vent.		Measure across vent to edge.		Measure waist at specified distance down from: (A) HPS, (B) CB Neckline, or (C) Below Armhole at side of garment.	
					



HTM Guide

	Product Flex # :	144462	Name :	TD Template Product	Flex Spec ID :	91666
	Primary Catalog :		Seasonal Selling Quarter :		Season Name :	Fall 2014
Merchandiser :	PC - Chelsea Olm	Product Designer :		Tech Designer :		QA Technologist :
SFC :		Vendor :	GSO TBD	Sourcing :		GSO Tracking # :
Pack Number :		Size Definitions :	Womens Numeric---:6-24W, Womens Alpha---:S-3X, One Size---:One Size-One Size	Vendor Item # :		

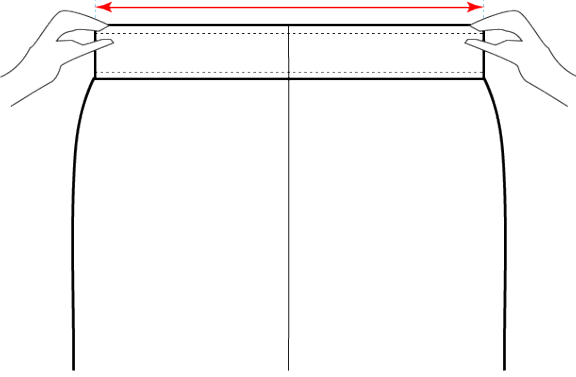
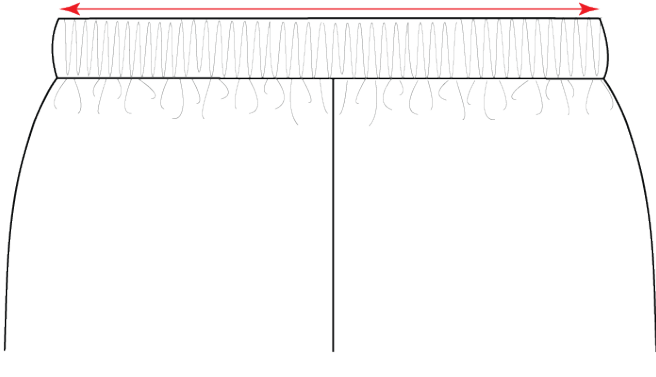
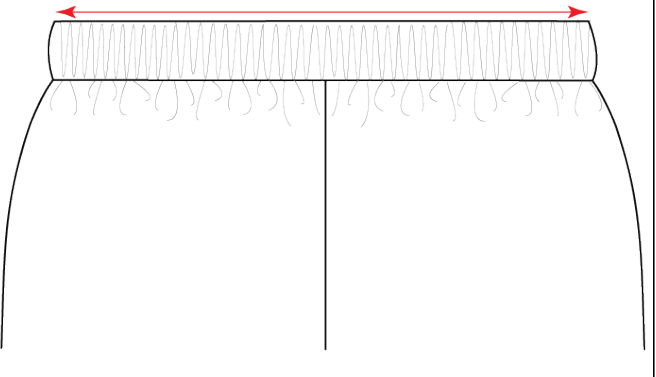
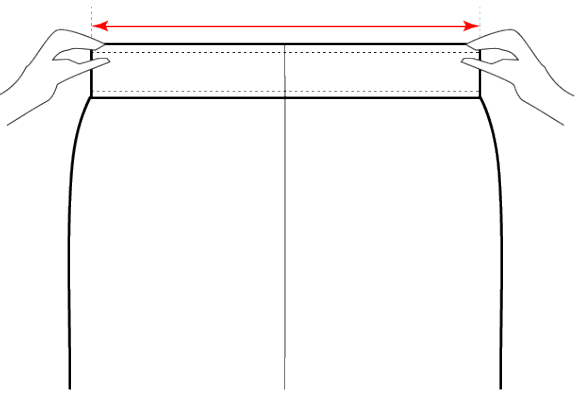
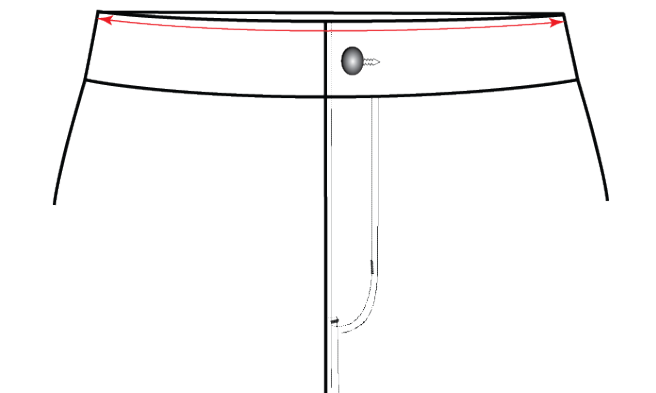
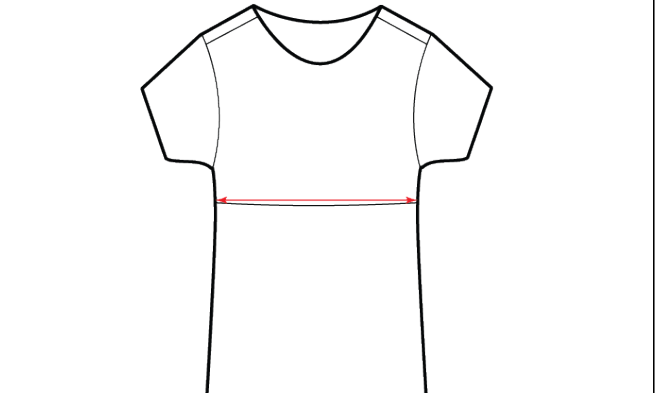
WA02-E	Back Waist Panel- Extended (bottom) 1/2 Grade	WA02-R	Back Waist Panel-Relaxed (bottom) 1/2 Grade	WA03	Waist Relaxed
<p>With fingers inside waist stretch back to maximum. Measurement must be met at top edge of opening and at seam or stitching if present. Do Not Over Extend Waistband when measuring.</p>		<p>Measure straight along top of back waistband from edge to edge.</p>		<p>Align front and back, waistlines to be even along top of edge. Measure straight along top of waistband from outside edge to outside edge (circum).</p>	
					
WA04	Waist Extended	WA05	Waist at Top Edge of Waistband	WA06	Empire Waist @ seam
<p>With fingers inside waist stretch to maximum. Measurement given is a minimum measurement and must be met at top edge of opening and at seam or stitching if present (circum).</p>		<p>Align front and back waist at top edge. Measure from edge to edge along top edge of pant.</p>		<p>Measure waist at midriff seam straight across from edge to edge (circum).</p>	
					

HTM Guide

	Product Flex # :	144462	Name :	TD Template Product	Flex Spec ID :	91666
	Primary Catalog :		Seasonal Selling Quarter :		Season Name :	Fall 2014
Merchandiser :	PC - Chelsea Olm	Product Designer :		Tech Designer :		QA Technologist :
SFC :		Vendor :	GSO TBD	Sourcing :		GSO Tracking # :
Pack Number :		Size Definitions :	Womens Numeric---:6-24W, Womens Alpha---:S-3X, One Size---:One Size-One Size	Vendor Item # :		

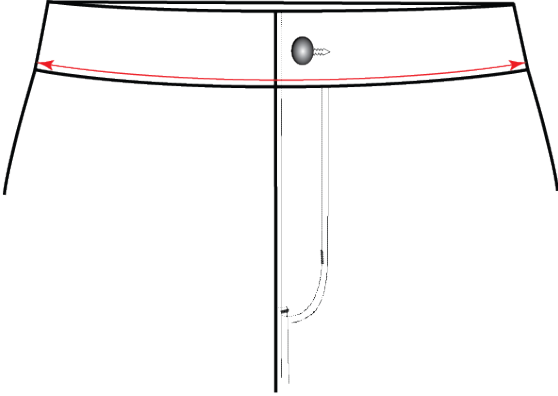
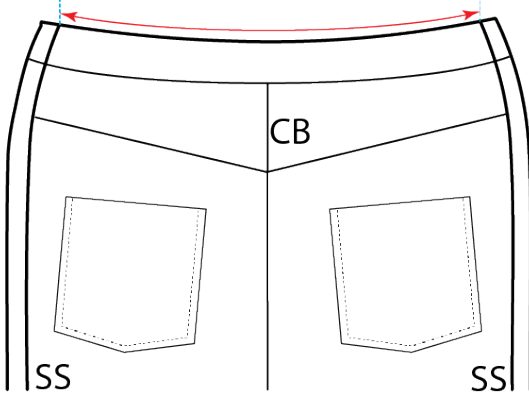
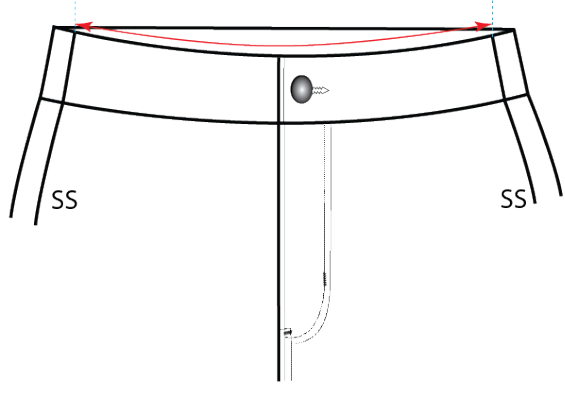
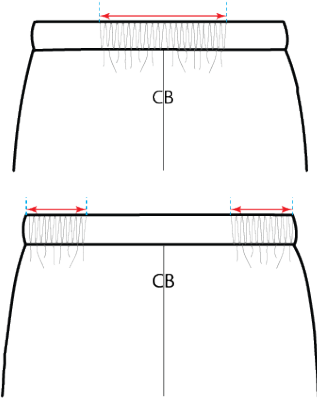
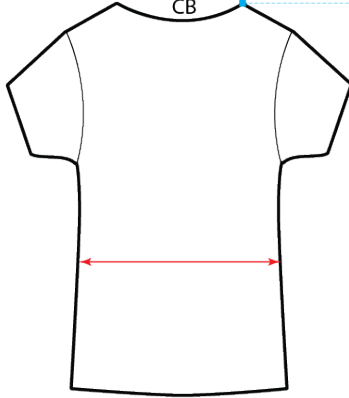
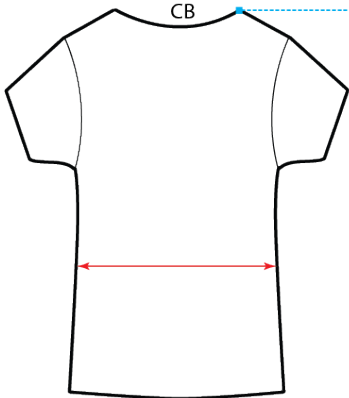
<p>WA07</p> <p>Waist at Bottom Waistband Seam</p> <p>Align front and back waist at top edge. Measure from edge to edge along the waistband seam.</p> 	<p>WA08</p> <p>Back Waist- Side Seam to Side Seam (1/2 Grade)</p> <p>Measure back waistband at top edge from side seam (SS) to side seam.</p> 	<p>WA09</p> <p>Front Waist - SS to SS (1/2 Grade)</p> <p>Measure front waistband at top edge from side seam (SS) to side seam. All closures must be fastened.</p> 
<p>WA10</p> <p>Side Waist Elastic Length @ Specified Place</p> <p>Measure relaxed length of elastic from end to end, at specified location, (usually CB or Side/Back).</p> 	<p>WA11</p> <p>Back Waist @ Spec Location (Full Grade)</p> <p>Measure waist at specified distance down from high point shoulder (HPS) straight across from edge to edge (circum).</p> 	<p>WA12</p> <p>Back Waist @ Spec Location (1/2 Grade)</p> <p>Measure waist at specified distance down from high point shoulder (HPS) straight across from edge to edge.</p> 

HTM Guide

	Product Flex # :	144462	Name :	TD Template Product	Flex Spec ID :	91666
	Primary Catalog :		Seasonal Selling Quarter :		Season Name :	Fall 2014
Merchandiser :	PC - Chelsea Olm	Product Designer :	Tech Designer :	QA Technologist :		
SFC :		Vendor :	GSO TBD	Sourcing :	GSO Tracking # :	
Pack Number :		Size Definitions :	Womens Numeric---:6-24W, Womens Alpha---:S-3X, One Size---:One Size-One Size	Vendor Item # :		

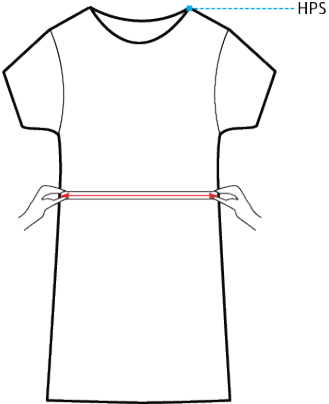
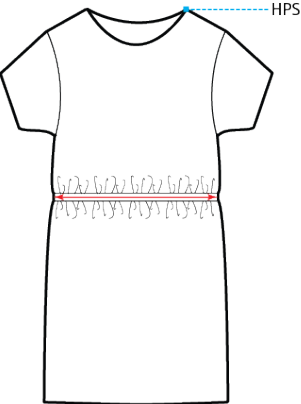
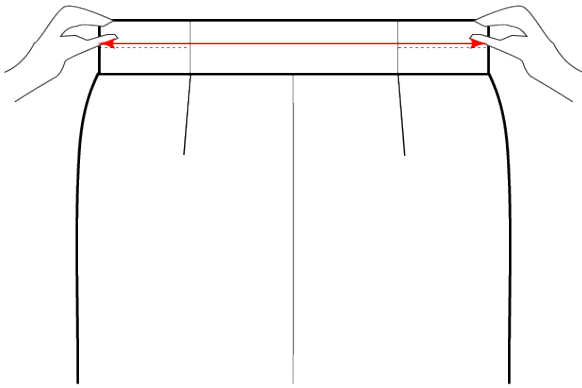
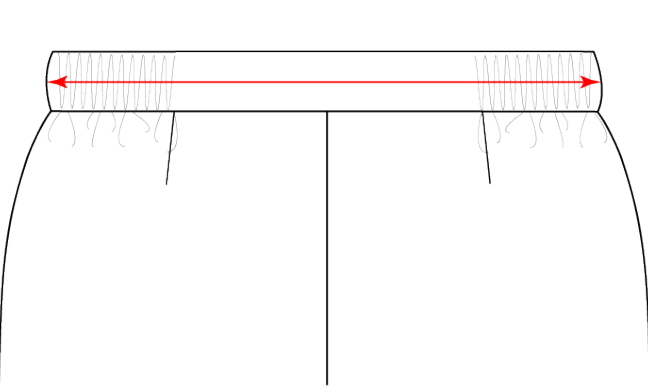
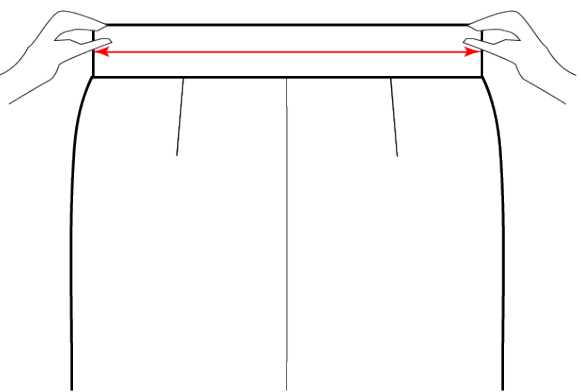
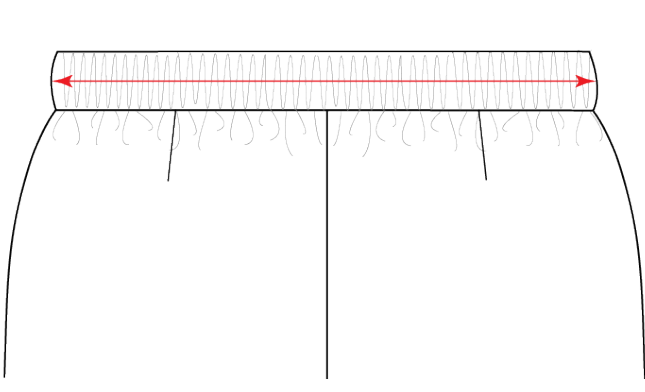
WA13-E	Waist Circumference Extended (top)	WA13-R	Waist Circumference Relaxed (top)	WA14-E	Waist - side back elastic extended
<p>With fingers outside waist, stretch to maximum. Measure straight across from side seam (SS) to side seam (SS) at center of elastic/waistband, unless otherwise noted (circum).</p>		<p>Measure straight across from side seam (SS) to side seam (SS) at center of elastic/waistband, unless otherwise noted (circum).</p>		<p>With fingers inside waist stretch to maximum. Measurement given is a minimum measurement and must be met at top edge of opening and at seam or stitching if present (circumference).</p>	
					
WA14-R	Waist - side back elastic relaxed	WA15-E	Waist - elastic all around extended	WA15-R	Waist - Elastic all around relaxed
<p>Align front and back, waistlines to be even along top of edge. Measure straight along center of waistband from outside edge to outside edge (circumference).</p>		<p>With fingers inside waist stretch to maximum. Measurement given is a minimum measurement and must be met at top edge of opening and at seam or stitching if present (circumference).</p>		<p>Align front and back, waistlines to be even along top of edge. Measure straight along center of waistband from outside edge to outside edge (circumference).</p>	
					

## HTM Guide

	Product Flex # :	144462	Name :	TD Template Product	Flex Spec ID :	91666
	Primary Catalog :		Seasonal Selling Quarter :		Season Name :	Fall 2014
Merchandiser :	PC - Chelsea Olm	Product Designer :		Tech Designer :		QA Technologist :
SFC :		Vendor :	GSO TBD	Sourcing :		GSO Tracking # :
Pack Number :		Size Definitions :	Womens Numeric---:6-24W, Womens Alpha---:S-3X, One Size---:One Size-One Size	Vendor Item # :		

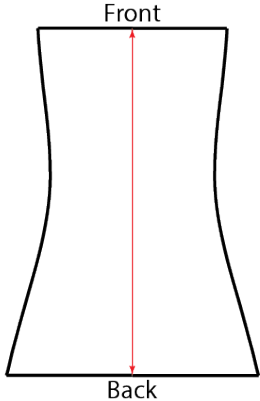
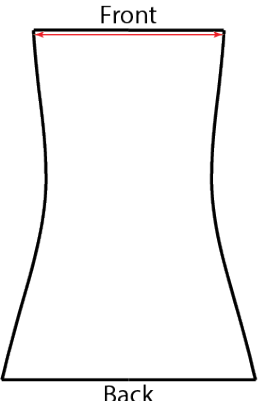
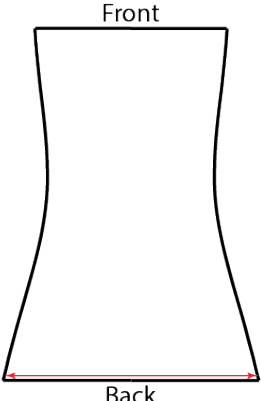
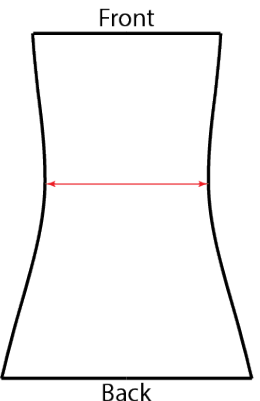
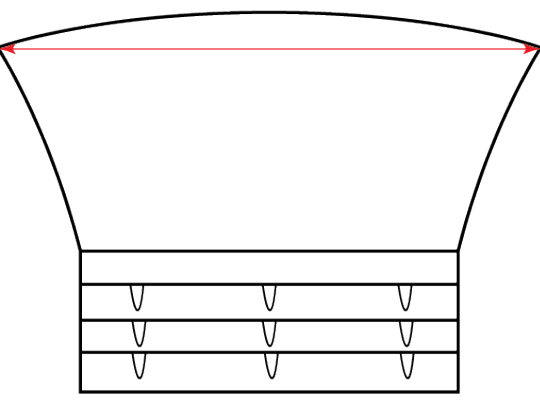
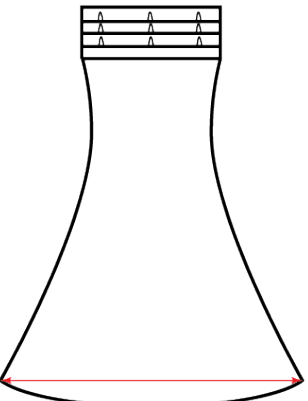
XC01	Crotch Panel Height At Center of Panel	XC03	Front Crotch Panel Width	XC04	Back Crotch Panel Width
Measure from front crotch seam to back seam, at the center of the panel.		Measure straight across from edge to edge/seam to seam. For garments without a separate crotch panel, measure total width of crotch lining edge to edge.		Measure straight across from edge to edge/seam to seam. For garments without a separate crotch panel, measure total width of crotch lining edge to edge.	
					
XC05	Crotch Panel Width at Narrowest Point	XC06	Front Crotch Extension Width At Join Seam	XC07	Back Crotch Extension Width At Join Seam
Determine the narrowest portion of the panel. Measure straight across from edge to edge/seam to seam. For garments without a separate crotch panel, measure total width of crotch lining edge to edge.		Measure straight across at crotch seam. Measure from Edge to Edge. Do Not Follow Curve.		Measure straight across at crotch seam. Measure from Edge to Edge. Do Not Follow Curve.	
					

HTM Guide

	Product Flex # :	144462	Name :	TD Template Product	Flex Spec ID :	91666
	Primary Catalog :		Seasonal Selling Quarter :		Season Name :	Fall 2014
Merchandiser :	PC - Chelsea Olm	Product Designer :		Tech Designer :		QA Technologist :
SFC :		Vendor :	GSO TBD	Sourcing :		GSO Tracking # :
Pack Number :		Size Definitions :	Womens Numeric---:6-24W, Womens Alpha---:S-3X, One Size---:One Size-One Size	Vendor Item # :		

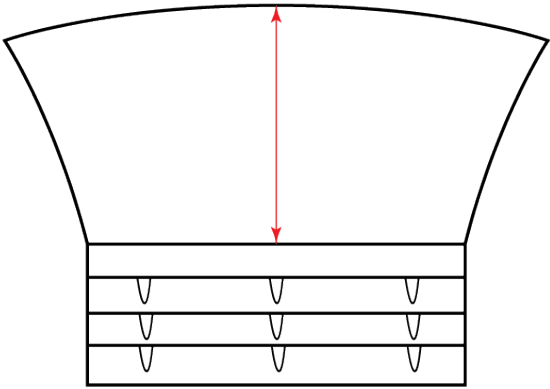
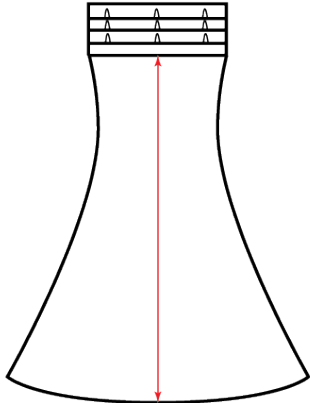
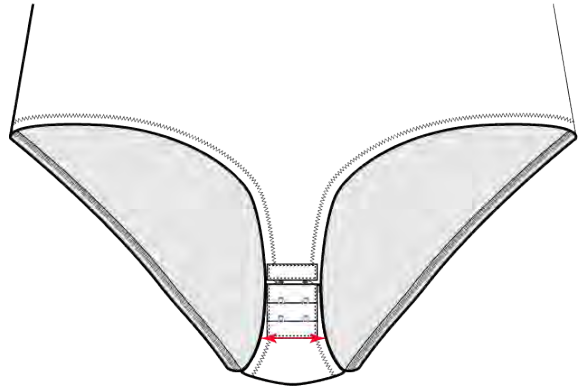
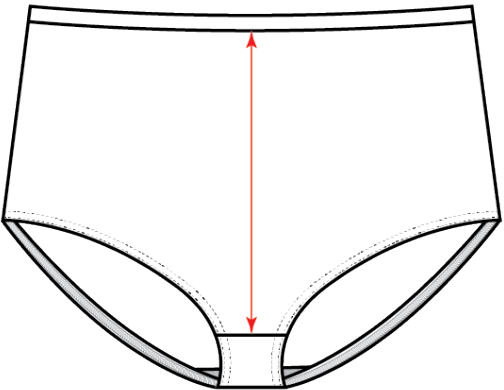
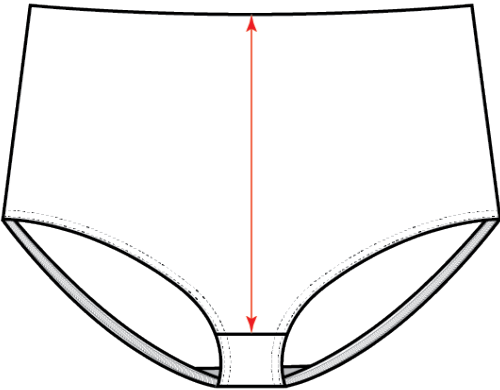
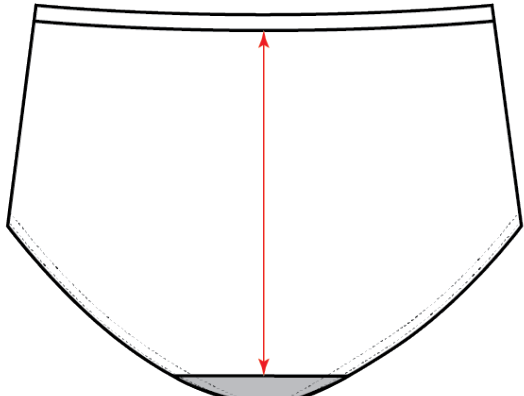
XC08	Front Crotch Extension Length	XC09	Back Crotch Extension Length	XC10	Back Crotch Panel Closure Width
Measure straight at center of panel, from crotch panel join seam to hook/eye attachment.		Measure straight at center of panel, from crotch panel join seam to hook/eye attachment.		Measure straight across from edge to edge/seam to seam.	
					
XL01	Front Panty Length Frm Waist Seam to Crotch Panel	XL01-T	Front Panty Length From Top Edge to Crotch Panel	XL02	Back Panty Length From Wstband Seam to Crotch Panel
Measure from the waistband seam to the crotch panel join seam.		Measure from the top of the waistband to the crotch panel join seam.		Measure from the waistband seam to the crotch panel join seam.	
					

## HTM Guide

	Product Flex # :	144462	Name :	TD Template Product	Flex Spec ID :	91666
	Primary Catalog :		Seasonal Selling Quarter :		Season Name :	Fall 2014
Merchandise :	PC - Chelsea Olm	Product Designer :	Tech Designer :	QA Technologist :		
SFC :		Vendor :	GSO TBD	Sourcing :	GSO Tracking # :	
Pack Number :		Size Definitions :	Womens Numeric---:6-24W, Womens Alpha---:S-3X, One Size---:One Size-One Size	Vendor Item # :		

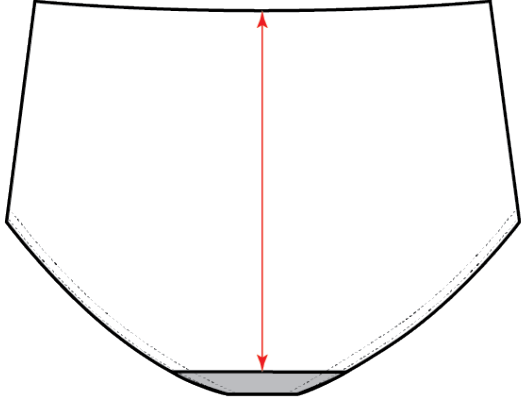
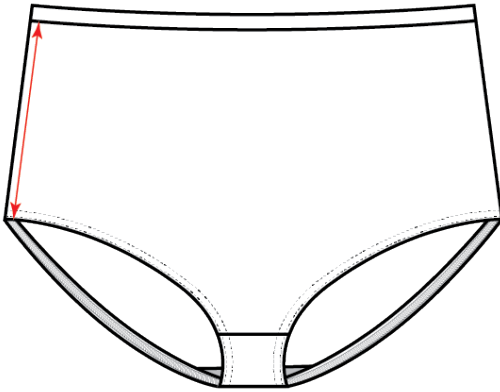
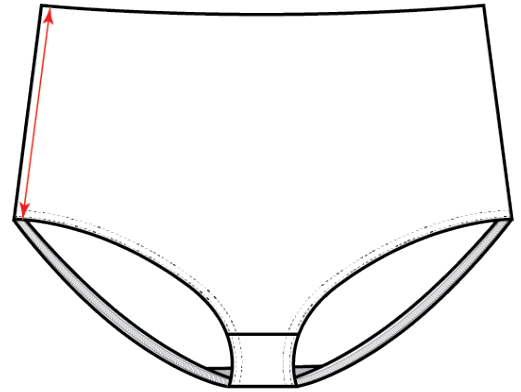
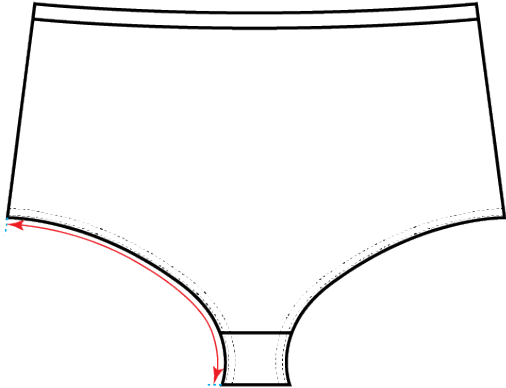
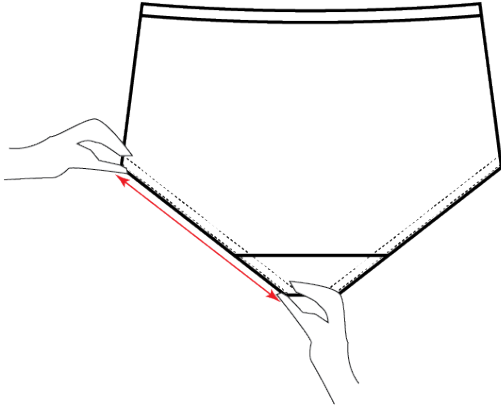
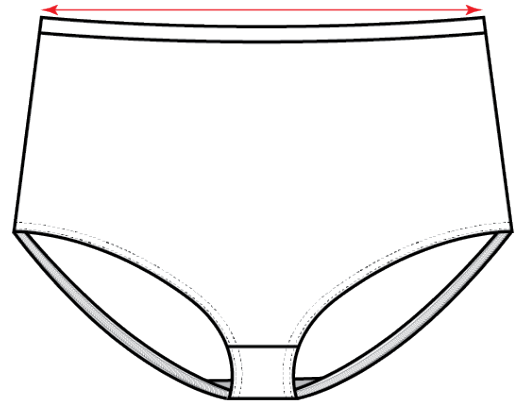
XL02-T	Back Panty Length From Top Edge to Crotch Panel	XL03	Side Panty From Waistband Seam To Leg Opening	XL03-T	Side Panty From Top Edge To Leg Opening
Measure from the top of the waistband (including trim) to the crotch panel join seam.		Measure along the side seam from the top edge of the leg opening. If the seam rolls to the front or back, measure along the natural fold of the panty while laying flat.		Measure along the side seam from the top edge of the leg opening. If the seam rolls to the front or back, measure along the natural fold of the panty while laying flat.	
					
XO01	Leg Opening Relaxed	XO02	Leg Opening Extended	XW01	Panty Waist Relaxed at Top Edge
Align front and back leg opening. With tape measure standing up, measure along curve of panty. Double the measurement.		Measure leg opening from side seam/fold to fold, overextending elastic.		Measure top edge of garment from side seam/seam or fold to fold with the garment relaxed.	
					

## HTM Guide

	Product Flex # :	144462	Name :	TD Template Product	Flex Spec ID :	91666
	Primary Catalog :		Seasonal Selling Quarter :		Season Name :	Fall 2014
Merchandise :	PC - Chelsea Olm	Product Designer :	Tech Designer :	QA Technologist :		
SFC :		Vendor :	GSO TBD	Sourcing :	GSO Tracking # :	
Pack Number :		Size Definitions :	Womens Numeric---:6-24W, Womens Alpha---:S-3X, One Size---:One Size-One Size	Vendor Item # :		

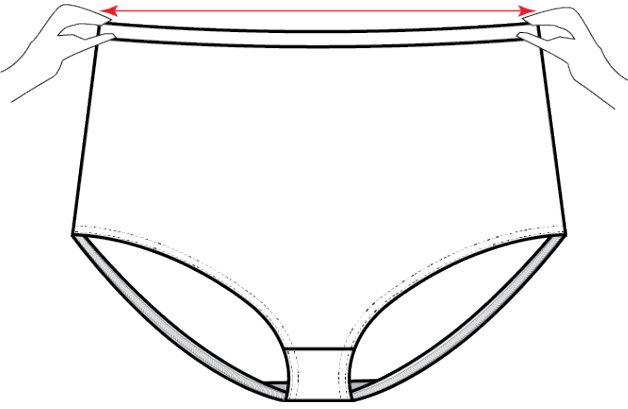
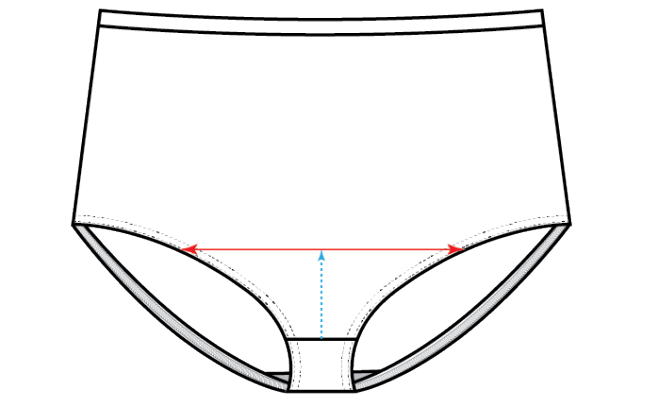
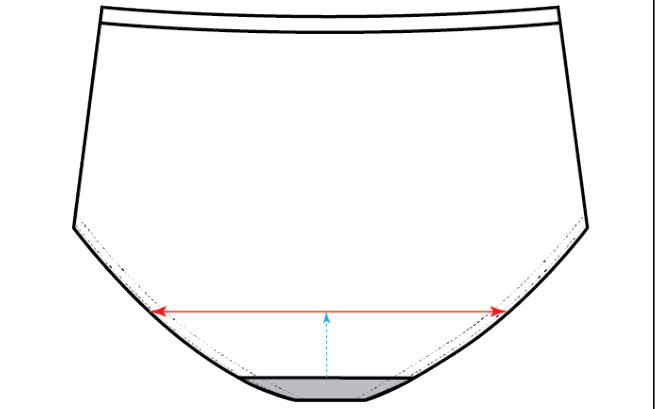
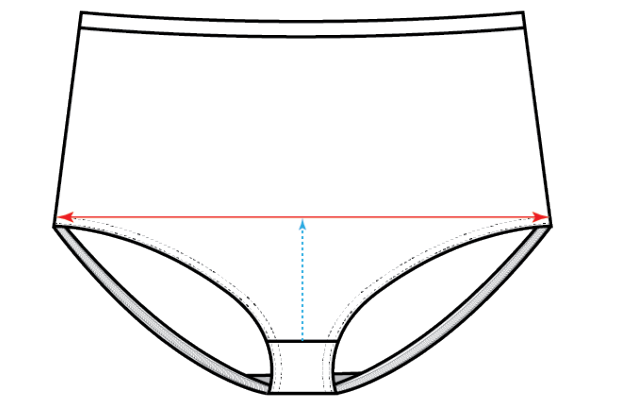
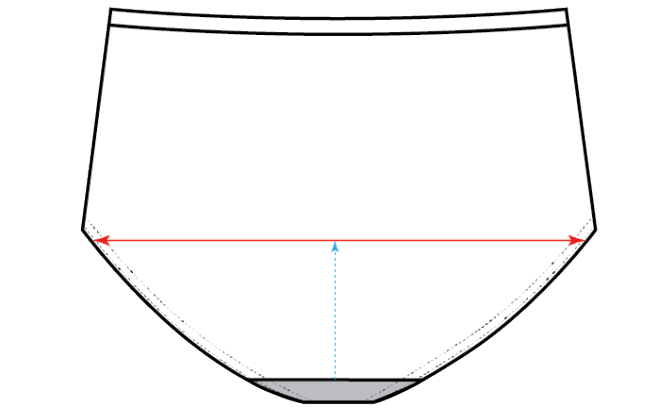
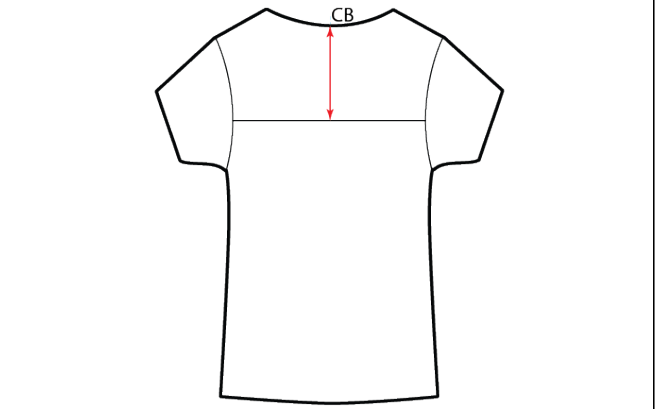
XW02	Panty Waist Extended at Top Edge	XW03	Front Panty Width at 2" From Crotch Seam	XW04	Back Panty Width at 2" From Crotch Seam
Measure top edge of garment from side seam/fold to side seam/fold with garment relaxed, overextending garment.		Measure garment at 2" from front crotch panel seam. Measure garment from edge to edge (Including trim) or Seam to Seam (Excluding Trim).		Measure garment at 2" from front crotch panel seam. Measure garment from edge to edge (Including trim) or Seam to Seam (Excluding Trim).	
					
XW05	Front Panty Width at 4" From Crotch Seam	XW06	Back Panty Width at 4" From Crotch Seam	YH01	Yoke Height at Center Back Neckline
Measure garment at 4" from front crotch panel seam. Measure garment from edge to edge (Including trim) or Seam to Seam (Excluding Trim).		Measure garment at 4" from front crotch panel seam. Measure garment from edge to edge (Including trim) or Seam to Seam (Excluding Trim).		Measure straight from center back (CB) neck edge/Seam to yoke seam.	
					

HTM Guide

	Product Flex # :	144462	Name :	TD Template Product	Flex Spec ID :	91666
	Primary Catalog :		Seasonal Selling Quarter :		Season Name :	Fall 2014
Merchandiser :	PC - Chelsea Olm	Product Designer :		Tech Designer :		QA Technologist :
SFC :		Vendor :	GSO TBD	Sourcing :		GSO Tracking # :
Pack Number :		Size Definitions :		Womens Numeric---:6-24W, Womens Alpha---:S-3X, One Size---:One Size-One Size		Vendor Item # :

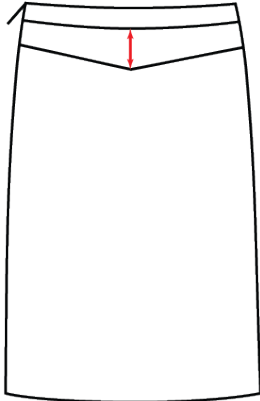
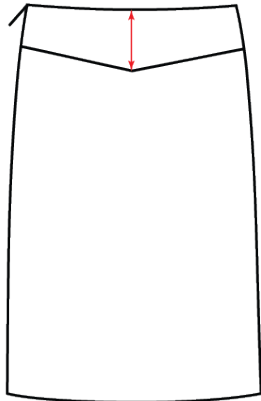
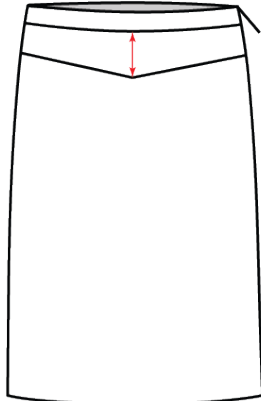
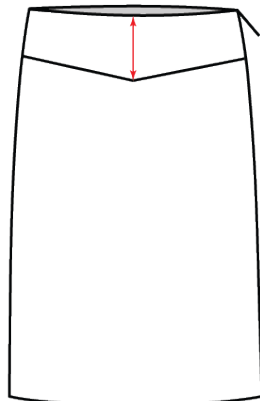
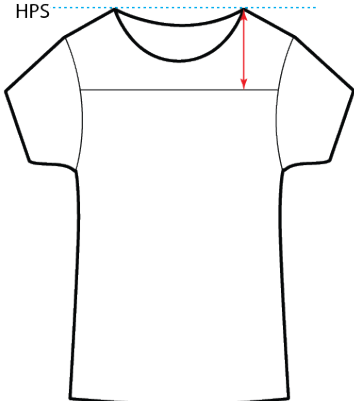
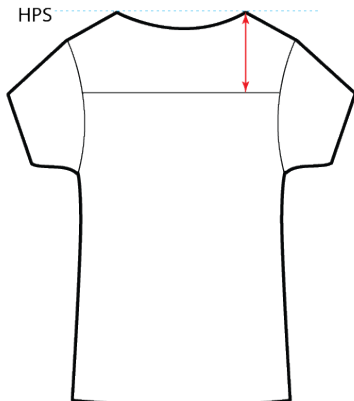
YH02	CB Yoke Height- Below WB Seam (Bottom)	YH02-T	CB Yoke Height- Below Top Edge (Bottom)	YH03	CF Yoke Height- Below WB Seam (Bottom)
Measure yoke straight from bottom edge of waistband to bottom edge at center back.		Measure yoke straight from top edge of waist to bottom edge at center back.		Measure yoke straight from bottom edge of waistband to bottom edge at center front.	
					
YH03-T	CF Yoke Height- Below Top Edge (Bottom)	YH04	Front Yoke Height From HPS (top)	YH05	Back Yoke Height From HPS (top)
Measure yoke straight from top edge of waist to bottom edge at center front.		Measure straight down from HPS to edge of yoke.		Measure straight down from HPS to Back yoke seam.	
					



HTM Guide

	Product Flex # :	144462	Name :	TD Template Product	Flex Spec ID :	91666
	Primary Catalog :		Seasonal Selling Quarter :		Season Name :	Fall 2014
Merchandise :	PC - Chelsea Olm	Product Designer :		Tech Designer :		QA Technologist :
SFC :		Vendor :	GSO TBD	Sourcing :		GSO Tracking # :
Pack Number :		Size Definitions :		Womens Numeric---:6-24W, Womens Alpha---:S-3X, One Size---:One Size-One Size		Vendor Item # :

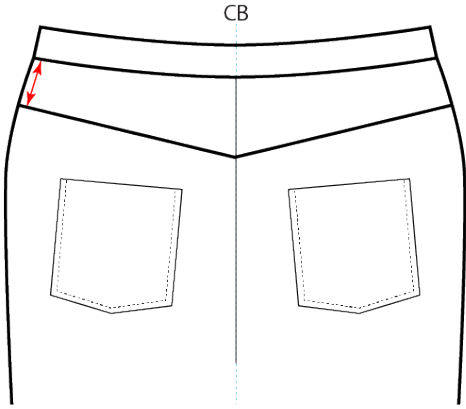
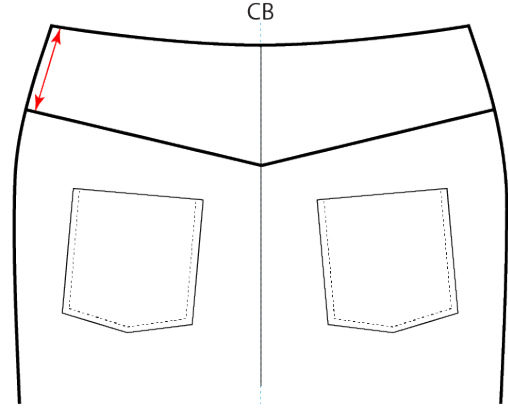
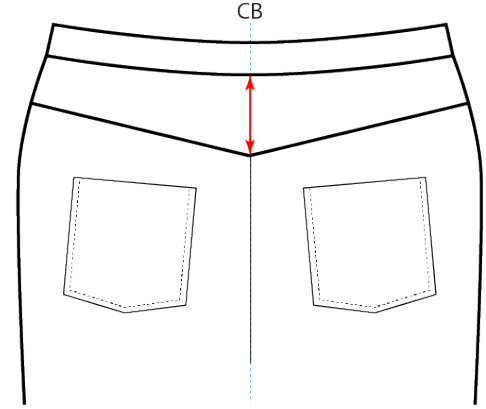
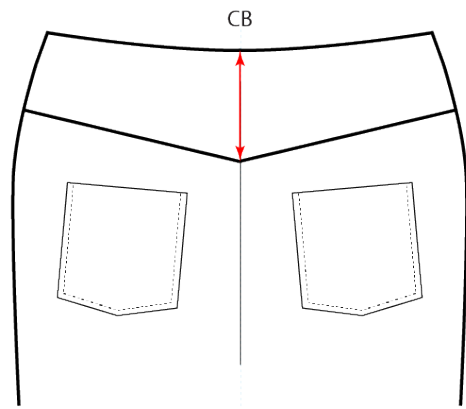
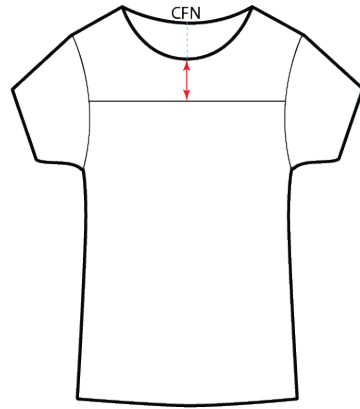
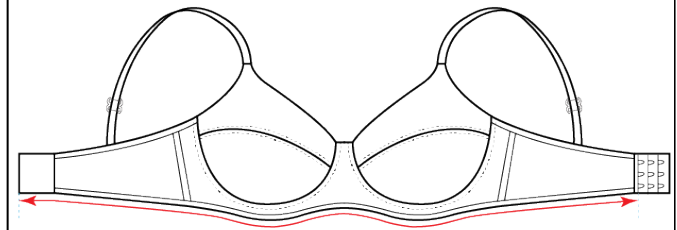
YH06	Yoke Height at Side Seam- Below WB (Bottom)	YH06-T	Yoke Height at Side Seam- From Top Edge (Bottom)	YH07	Yoke Height at CB-Below WB (Bottom)
Measure from below waistband at the side seam, to yoke seam.		Measure from top of waist at the side seam, to yoke seam.		Measure straight at center back below waistband to yoke seam.	
					
YH07-T	Yoke Height at CB- From Top Edge (Bottom)	YH08	Yoke Height frm CF (no grade)	ZB002	BANDED Bottom Band Length -1st Hook to 1st Eyes
Measure straight at center back from top of waist to yoke seam.		Measure straight from center front (CF) neck edge to bottom of yoke.		Lay garment flat and measure along the edge of the bottom band. Measure from 1st set of hooks to 1st set of eyes.	
					

HTM Guide

	Product Flex # :	144462	Name :	TD Template Product	Flex Spec ID :	91666
	Primary Catalog :		Seasonal Selling Quarter :		Season Name :	Fall 2014
Merchandise :	PC - Chelsea Olm	Product Designer :		Tech Designer :		QA Technologist :
SFC :		Vendor :	GSO TBD	Sourcing :		GSO Tracking # :
Pack Number :		Size Definitions :	Womens Numeric---:6-24W, Womens Alpha---:S-3X, One Size---:One Size-One Size	Vendor Item # :		

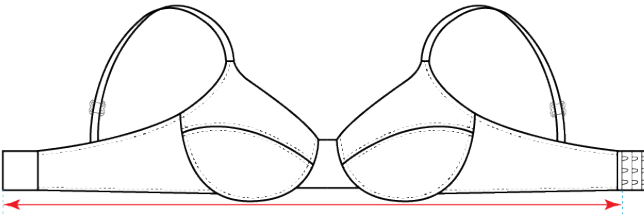
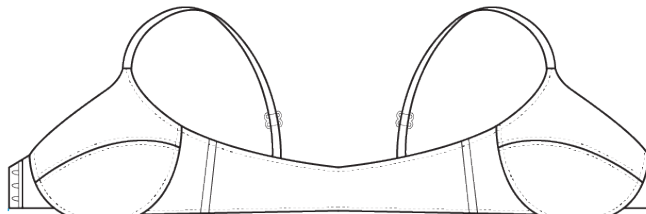
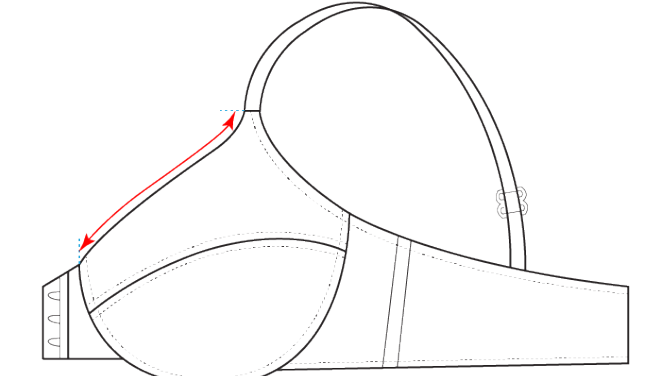
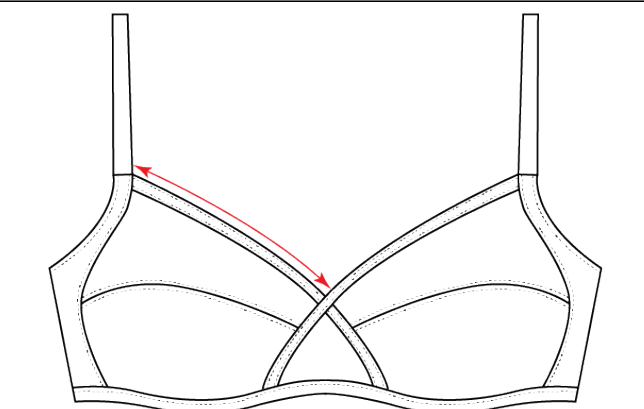
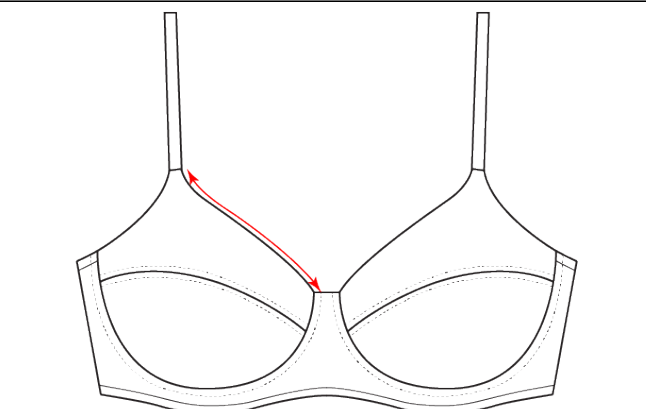
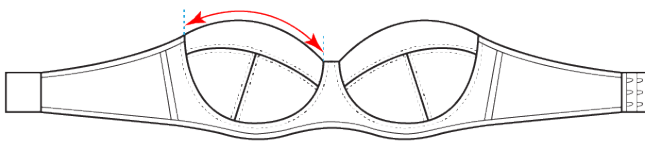
ZB004	NON-BANDED Bottom Band Length-1st Hook to 1st Eyes	ZB008	FRONT CLOSURE BRA - Bottom Band Length	ZB016	Front Closure Bra- Top Cup Length from Strap Join
Lay garment flat and measure bottom edge, from hook to 1st eye. Measure straight across the bottom of the bra. Do not measure over the wire/cup.		Lay garment flat and measure bottom from end of center front closure to end of the centre front closure. If Garment has Hook/Eye Closure, measure from 1st set of Hooks, to first set of eye.		Lay garment flat, and measure along top of curve. Measure from strap join to Cup Seam/Casing Stitchline. Do Not Measure Hardware/CF Gore	
					
ZB022	Cup Length From Strap Join to CF Join- No Gore	ZB030	Cup Length at Top of Cup- From Strap Join	ZB040	STRAPLESS- Front Cup Length at Top of Cup
Lay garment flat, and measure from strap join to center front seam.		Lay garment flat, and measure from strap join to casing seam. Measure along curve of cup.		Lay garment flat, and measure from join cup seam to cup seam, along the top of the cup.	
					

HTM Guide

	Product Flex # :	144462	Name :	TD Template Product	Flex Spec ID :	91666
	Primary Catalog :		Seasonal Selling Quarter :		Season Name :	Fall 2014
Merchandise :	PC - Chelsea Olm	Product Designer :		Tech Designer :		QA Technologist :
SFC :		Vendor :	GSO TBD	Sourcing :		GSO Tracking # :
Pack Number :		Size Definitions :	Womens Numeric---:6-24W, Womens Alpha---:S-3X, One Size---:One Size-One Size	Vendor Item # :		

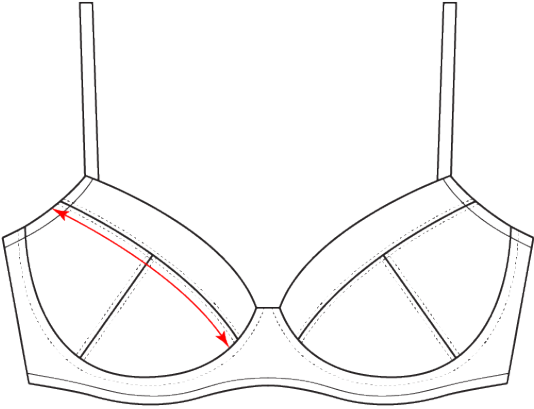
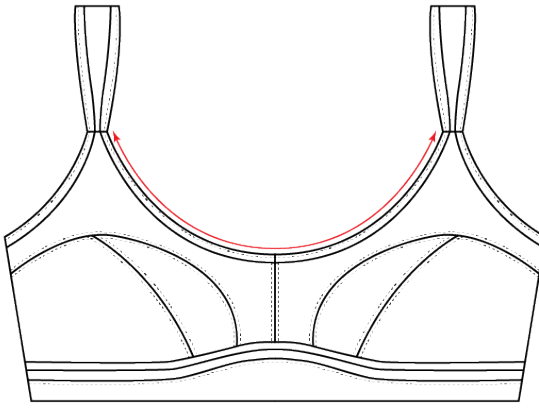
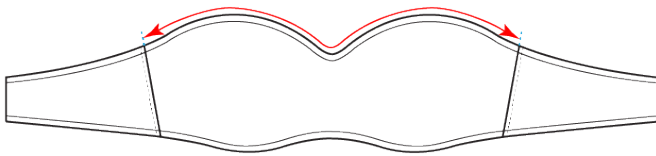
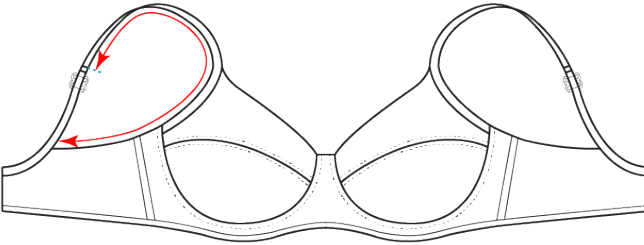
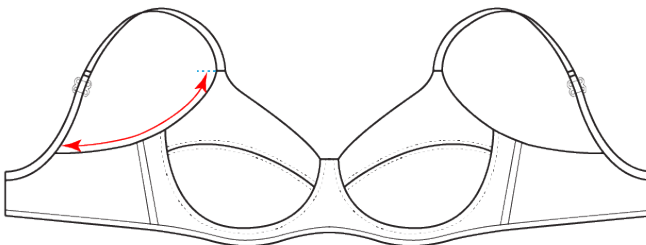
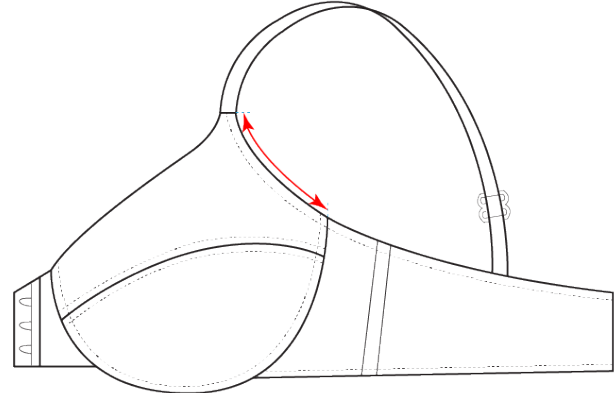
ZB052	Cup Seam Length- Armhole to CF Gore	ZB056	Front Neck Length Strap to Strap- Seamed Sft Cup	ZB058	Strapless Neckline from Seam to Seam
Lay garment flat. Measure from armhole to center front gore, along the cup seam.		Lay garment flat, and measure from front strap join to front strap join. Measure with tape measure standing up along edge.		Lay garment flat and measure from side seam to side seam, along top edge of neckline.	
					
ZB072	Underarm- Bck Strap to Frnt Strap >12".	ZB078	Underarm- Half Strap-Front Cup to Back Strap	ZB080	Underarm- From Strap Join To Casing Seam
Lay garment flat, and measure strap along inside edge. Measure from Back Strap join to Front Strap Join.		Lay garment flat, and measure from front strap join seam to the back strap join.		Measure from the top of the cup, at the strap join, to the casing seam. Measure with tape measure standing upright, along curve.	
					

HTM Guide

	Product Flex # :	144462	Name :	TD Template Product	Flex Spec ID :	91666
	Primary Catalog :		Seasonal Selling Quarter :		Season Name :	Fall 2014
Merchandiser :	PC - Chelsea Olm	Product Designer :	Tech Designer :	QA Technologist :		
SFC :		Vendor :	GSO TBD	Sourcing :	GSO Tracking # :	
Pack Number :		Size Definitions :	Womens Numeric---:6-24W, Womens Alpha---:S-3X, One Size---:One Size-One Size	Vendor Item # :		

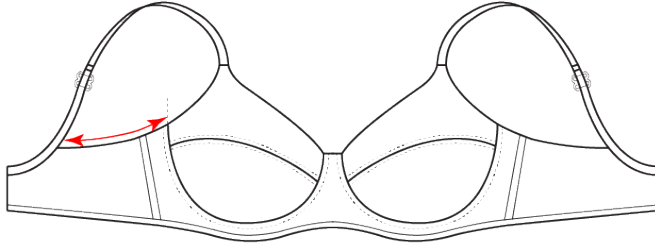
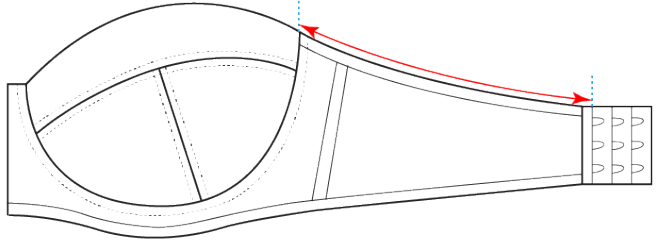
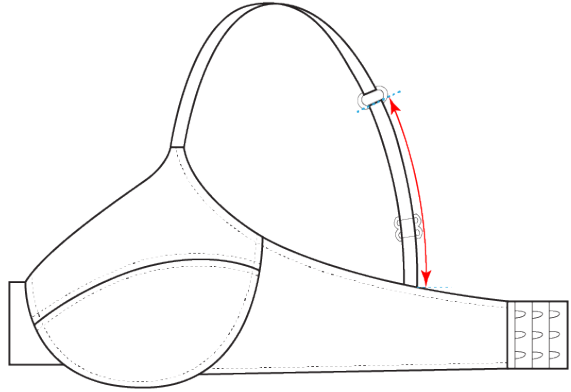
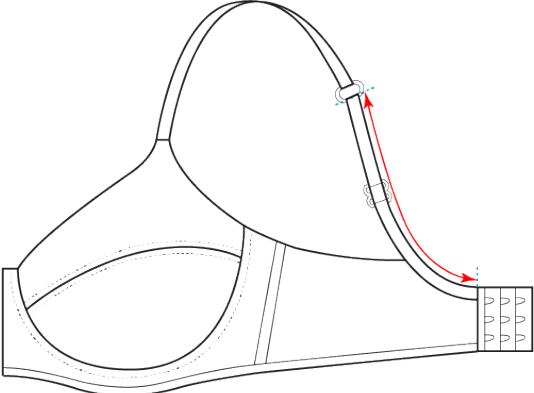
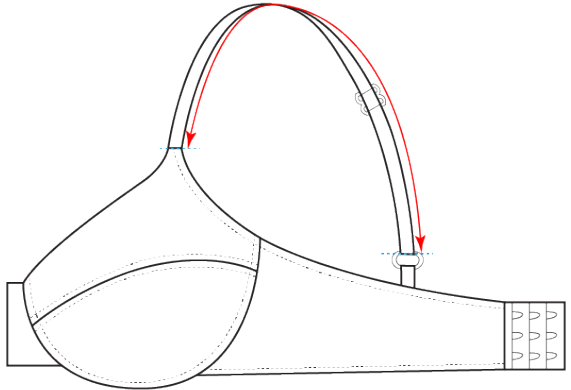
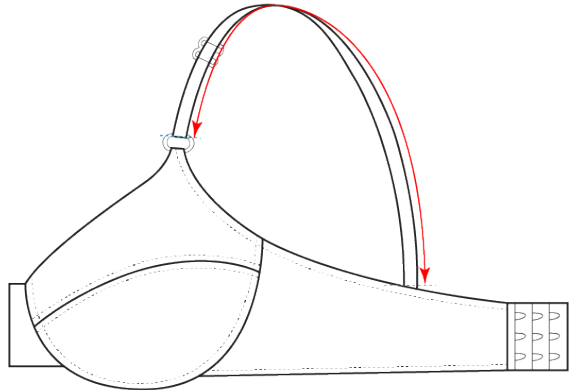
ZB092	Underarm- Cup Seam to Back Hardware.	ZB100	Underarm- Cup Seam to Hook or Eye, Strapless	ZB110	Strap Length, Short
Lay garment flat. Measure from the front cup casing seam to the back strap join. Measure along curve, with tape measure standing upright.		Lay garment flat, and measure from join cup seam to 1st hook or eye		Lay garment flat, and measure back strap from join to end excluding hook and eye. Strap to be adjusted to 3".	
					
ZB112	Strap Length, Cami Short	ZB114	Strap Length, Std Ring Back	ZB116	Strap Length, Std Ring Front
Lay garment flat, and measure back strap from join to end excluding hook and eye. Strap to be adjusted to 3".		Lay garment flat, and measure from join to end excuding hardware.		Lay garment flat, and measure from shoulder strap from join to end excluding hardware.	
					

HTM Guide



Product Flex # : 144462  
 Primary Catalog :

Name : TD Template Product  
 Seasonal Selling Quarter :

Flex Spec ID : 91666  
 Season Name : Fall 2014

Merchandiser : PC - Chelsea Olm  
 SFC :

Product Designer :  
 Vendor : GSO TBD

Tech Designer :  
 Sourcing :

QA Technologist :  
 GSO Tracking # :

Pack Number : Size Definitions :

Womens Numeric---:6-24W,  
 Womens Alpha---:S-3X, One  
 Size---:One Size-One Size

Vendor Item # :

<p>ZB118 Strap Length, CAmi Std</p>	<p>ZB122 Strap Length, Ext. to Tab</p>	<p>ZB124 Strap Length, to Bottom Elastic</p>
<p>Lay garment flat, and measure from join to end excluding hardware</p>	<p>Lay garment flat, and measure from shoulder strap from join to end, excluding hardware.</p>	<p>Lay garment flat, and measure from shoulder strap from join to end, excluding hardware.</p>
<p>ZB128 Strap Extension, Narrow</p>	<p>ZB130 Strap Extension, Wide</p>	<p>ZB132 Casing Length Along Seam</p>
<p>Lay garment flat, and measure from strap piece/extension/comfort strap from join at the front to join at strap, excluding hardware.</p>	<p>Lay garment flat, and measure from strap piece/ extension/ comfort strap from join at front to join at strap, excluding hardware</p>	<p>With tape measure standing up, measure along the casing length, from edge to edge.</p>

HTM Guide



Product Flex # : 144462  
 Primary Catalog :

Name : TD Template Product  
 Seasonal Selling Quarter :

Flex Spec ID : 91666  
 Season Name : Fall 2014

Merchandiser : PC - Chelsea Olm  
 SFC :

Product Designer :  
 Vendor : GSO TBD

Tech Designer :  
 Sourcing :

QA Technologist :  
 GSO Tracking # :

Pack Number : Size Definitions :

Womens Numeric---:6-24W,  
 Womens Alpha---:S-3X, One  
 Size---:One Size-One Size

Vendor Item # :

<p>ZB136 Ballet Back Length- Strap Join To CB Panel</p>	<p>ZB142 Front Closure Back Length at TOP- Cup to Cup</p>	<p>ZB156 CF Gore Width at Top</p>
<p>Lay garment flat, and measure from back strap join to CB closure join seam</p>	<p>Lay garment flat, and measure along the back curve from cup seam to cup seam.</p>	<p>Measure from Seam to Seam at the top of the inset panel.</p>
<p>ZB158 CF Inset Width Bottom</p>	<p>ZB160 Strap Tab, Finished W/ Hardware</p>	<p>ZB164 Bottom Band of Wing</p>
<p>Measure from Seam to Seam at the bottom of the inset panel.</p>	<p>Lay garment flat, and measure from end of tab to join seam, excluding the hardware.</p>	<p>Lay garment flat, and measure from the outside of wire casing to hook or eye, excluding hook &amp; eye.</p>

HTM Guide

	Product Flex # :	144462	Name :	TD Template Product	Flex Spec ID :	91666
	Primary Catalog :		Seasonal Selling Quarter :		Season Name :	Fall 2014
Merchandiser :	PC - Chelsea Olm	Product Designer :		Tech Designer :		QA Technologist :
SFC :		Vendor :	GSO TBD	Sourcing :		GSO Tracking # :
Pack Number :		Size Definitions :	Womens Numeric---:6-24W, Womens Alpha---:S-3X, One Size---:One Size-One Size	Vendor Item # :		

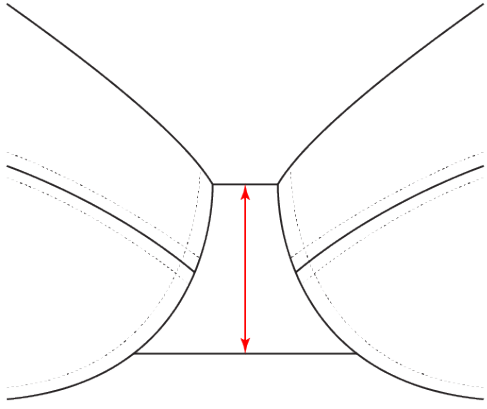
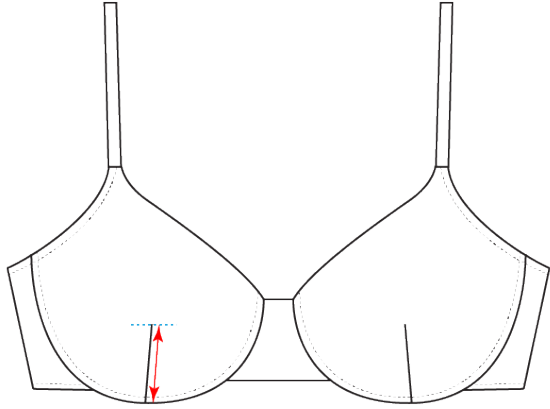
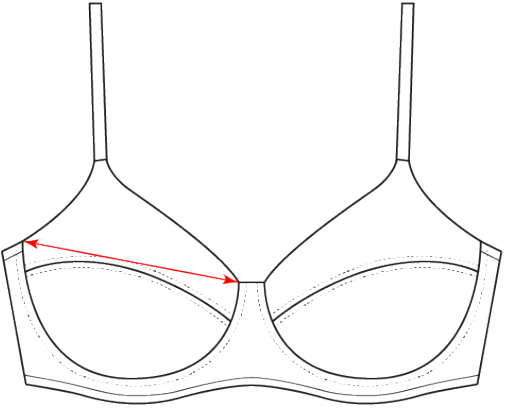
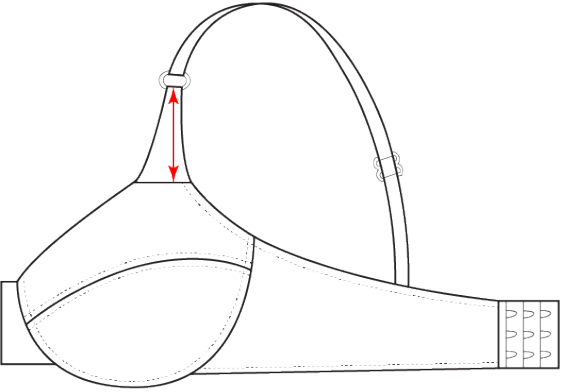
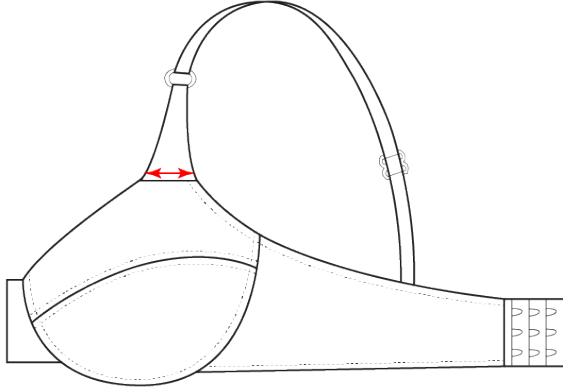
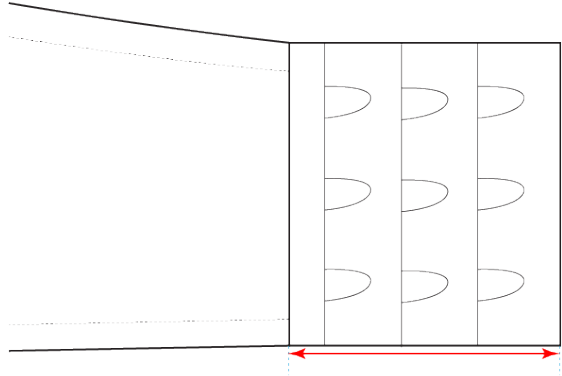
ZB174	Gore Height at Center Front	ZB176	Dart Length	ZB178	Distance from Wire to Wire at Top of Cup
Measure at center of gore (inset panel) from top edge to bottom edge.		Dart length from inside tubing to point		Measure straight across top of cup, from outside stitchline to outside stitchline.	
					
ZB181	Strap Inset Height	ZB182	Strap Inset Width	ZB184	Length of Hook/Eye Closure
Lay garment flat. Measure from front strap inset seam to top of strap join.		Lay garment flat. Measure strap inset with at the cup join seam.		Measure from Seam of Hook and Eye closure to the end of Hook and Eye Closure. Measure straight across.	
					

HTM Guide



Product Flex # : Primary Catalog :	144462	Name : Seasonal Selling Quarter :	TD Template Product	Flex Spec ID : Season Name :	91666 Fall 2014
Merchandiser : SFC :	PC - Chelsea Olm	Product Designer : Vendor :	Tech Designer : Sourcing :	QA Technologist : GSO Tracking # :	
Pack Number :		Size Definitions :	Womens Numeric---:6-24W, Womens Alpha---:S-3X, One Size---:One Size-One Size	Vendor Item # :	

ZB185	Height of Hook & Eye Closure	ZB189	Top Cup Height- at Widet Point	ZB190	Bottom Cup Height- at Center of Cup
Measure From the top of the Hook/Eye Closure to the Bottom of the Hook/Eye Closure. Edge to Edge.		Lay garment flat. Measure from top cup height at the widest point. Measure from Seam to Edge of panel.		Measure Bottom Cup Height at Center of Cup. Measure from Casing Seam to Top Cup Join Seam.	
ZP01	Zipper Length (bottom)	ZP02	Zipper Length @ CF (top)	ZP03	Zipper CB Dress
Measure zipper from zipper slider to bottom of metal stop.		Measure zipper length (closed) from top stop to bottom of bottom stop.		Measure zipper length (closed) from top stop to bottom of bottom stop.	



HTM Guide

	Product Flex # :	144462	Name :	TD Template Product	Flex Spec ID :	91666
	Primary Catalog :		Seasonal Selling Quarter :		Season Name :	Fall 2014
Merchandiser :	PC - Chelsea Olm	Product Designer :		Tech Designer :		QA Technologist :
SFC :		Vendor :	GSO TBD	Sourcing :		GSO Tracking # :
Pack Number :		Size Definitions :		Womens Numeric---:6-24W, Womens Alpha---:S-3X, One Size---:One Size-One Size		Vendor Item # :

ZP04	Zipper Length @ Side Seam (top)	ZP05	Zipper Skirt/Pant Side/CB
Measure zipper length (closed) from top stop to bottom of bottom stop.		Measure zipper from zipper slider to bottom of metal stop.	
